

Portfolio of Works : Jason SACHS 2024

Academic & Research / Technology + Design

ensa Grenoble

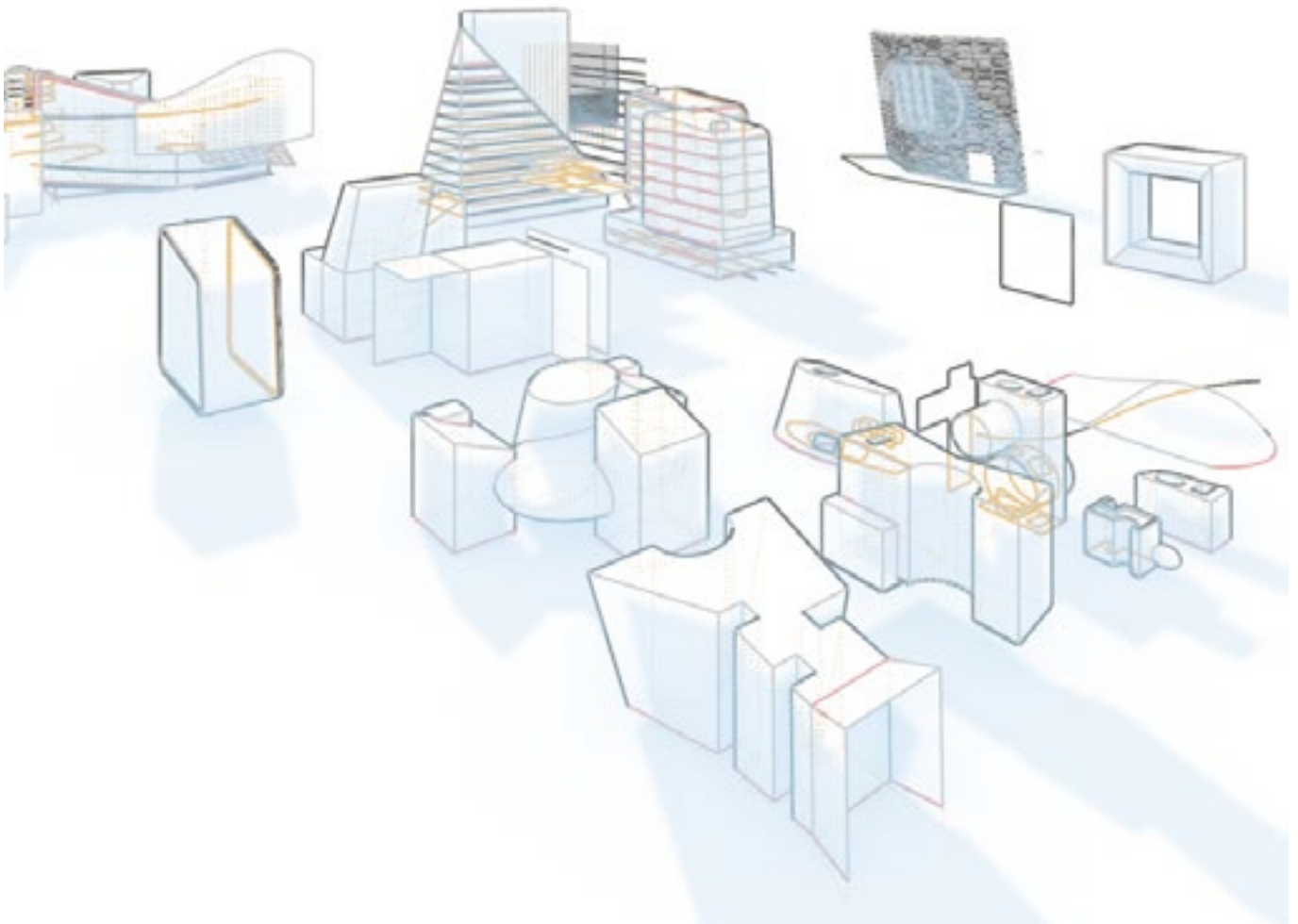

Short Bio of the candidate



Jason Sachs is an architect and designer who has worked on projects at every scale from the Chicago Spire and the largest women's university campus in the world, to furniture design, and jewelry. He has worked in massively multidisciplinary & multi-national teams and also as solo design/builder.

He has been experimenting with digital fabrication in project installations, since 2001.

He is a graduate of University of Illinois at Chicago Master of Architecture program and has an undergraduate degree in Geography from Boston University. He currently splits his time between teaching and practice based in France. He has taught at The School of the Art Institute of Chicago (SAIC). He currently teaches at école nationale supérieure d'architecture de Grenoble and previously at ensa Paris La Villette and Versailles.

Table of Contents

4	Systems :: Introduction
12	Models : Visualizing Volumetrically : Sketching & Drawing
20	Project Studio
26	Designing & Fabricating
30	Cartography : Urban Systems : Ecology
34	Research & Design Development
42	Professional & Personal Projects

System Model Analysis Integration Design

Structure Envelope Simulation Materiality

Construction Fabrication Site Ecology Design

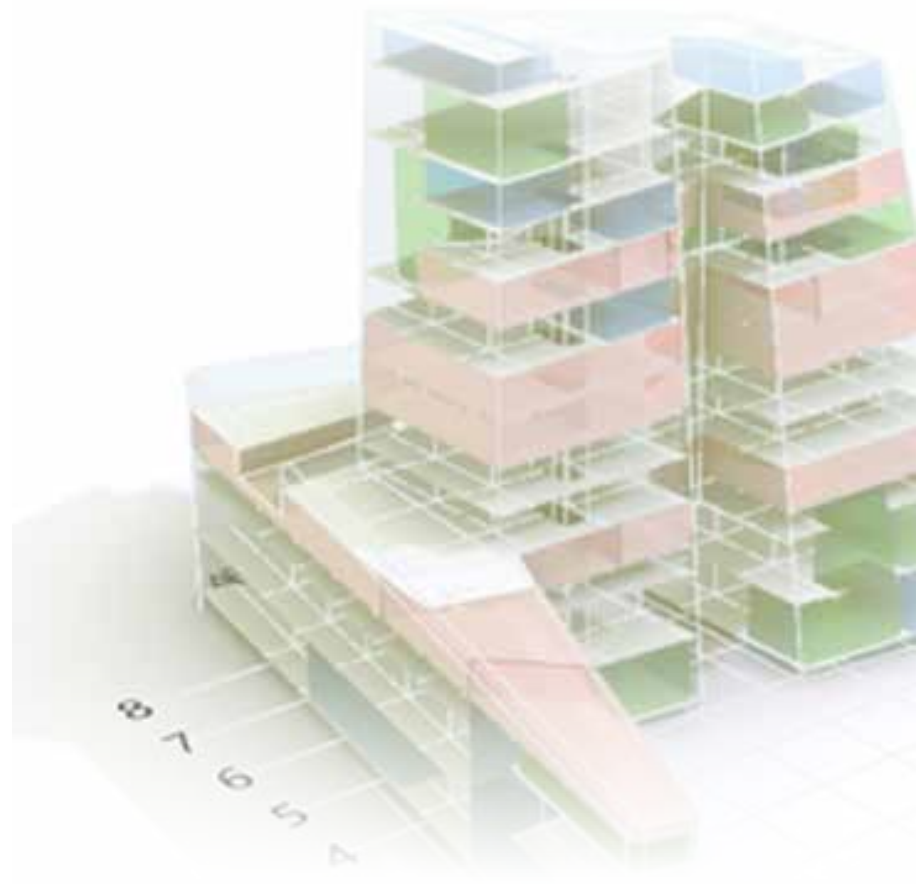
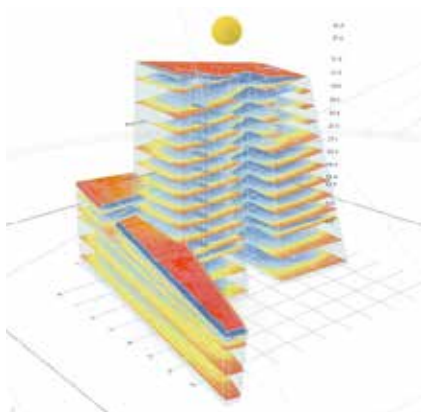
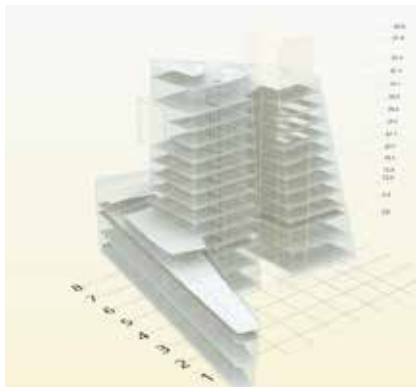
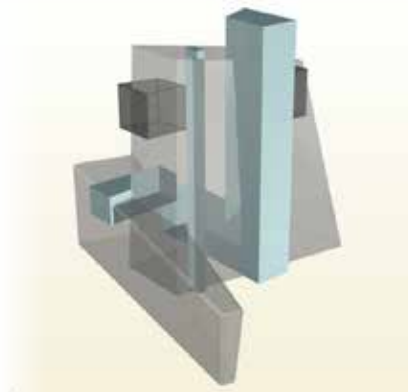

day1bim Tools
project model with
programming study

Modeling the physical material, the enclosure, the limits, the control geometry.

This introductory section is an overview of how I apply my experience to teaching systems & moreover teaching conceiving architecture.

Integration: Simulation Tectonic & Design

S901 Masters Year 2

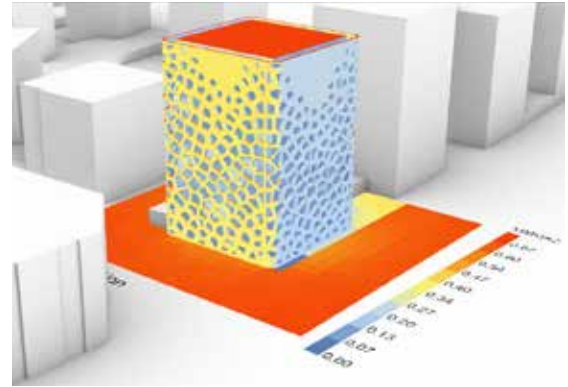
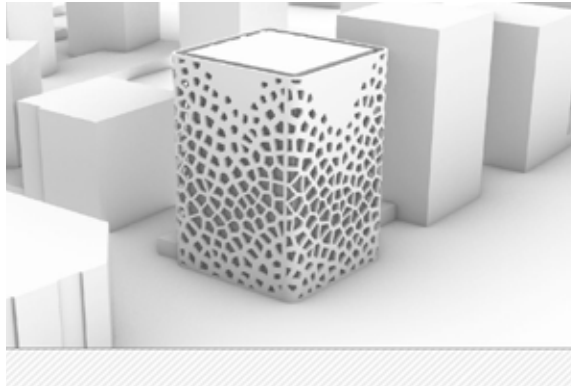

Conception d'une façade paramétrique

Recherche de références et écriture du script Grasshopper de conception de la façade



Warmińska Shopping Gallery
Kuryłowicz & Associates



Form finding
Angel Quintana



300 George Street
Alexander Knox

Outcomes of the facade
conception exercise

Setting up the conditions for
simulations.

Keryann Tisseur, 2021

**Articulating the tectonic;
what is its real form?
How do we experience it?**

S6RN Year 3 Undergrad

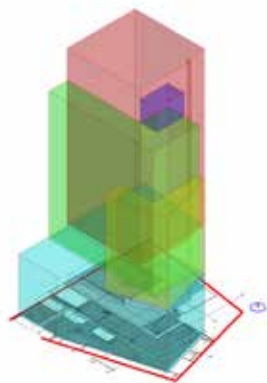

Outcomes of the facade
conception exercise

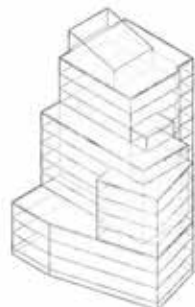

De l'assemblage de volumes conceptuels simples...

Development of the facade
from massing
Student 2021



... à l'élaboration d'un bâtiment complexe



Construction: Detail development of a complex façade

S6MN BIM Conception 3rd Year Undergrad



Exemple du détail (d'un autre projet) : Comprendre qu'il n'est pas atypique que le morceau bas du panel s'élève haut dessus de la surface du niveau. Cette distance dépend des propriétés du design.

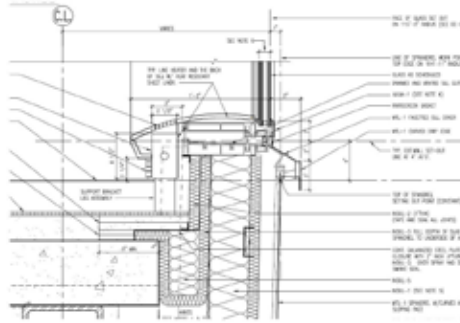

Construction :
Detail development
of a complex facade

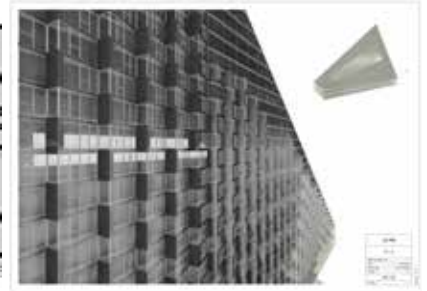

A second course in
BIM development.
The articulation of
a complex facade.
Project by Nada
ABSI 2022

PROJET WEST 57: MUR RIDEAU

7 Elevation Nord
Ech : 1 : 200

2 axo 2 groupes isolés
Ech :

10 3D-zone de coupe Copie 1
Ech :

1 3D des 2 groupes
Ech :

3 Niveau 2
Ech : 1 : 50

2 Vue coupée Grp OP
Ech :

6 Niveau 3
Ech : 1 : 50

4 Coupe no1
Ech : 1 : 50

4 Vue éclatée grp baie TRANS
Ech :

E NS/AG | UGA

Projet WEST 57

A2 TP4

Dessiné par Nada ABSI

Composed System Models: S902 Conception Digital & Collaborative

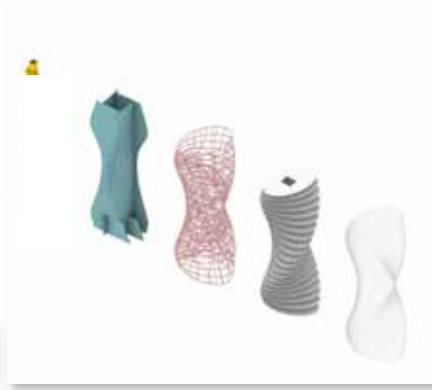

System models like these can be used to extract the geometry from a concept project and use that geometry as a base to apply the teaching of architectural systems. These models are from a course in collaborative conception. Teams of 4-5 generate three options with the systems models and simulations. This is done in 2-3 days of class work.

Composed System Models:
S902 Conception Digital & Collaborative
5th Year Masters 2

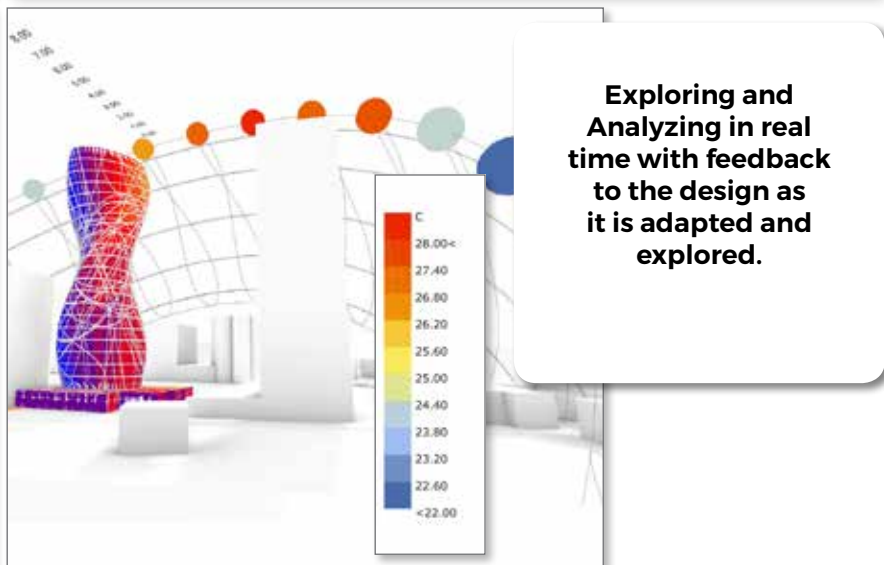
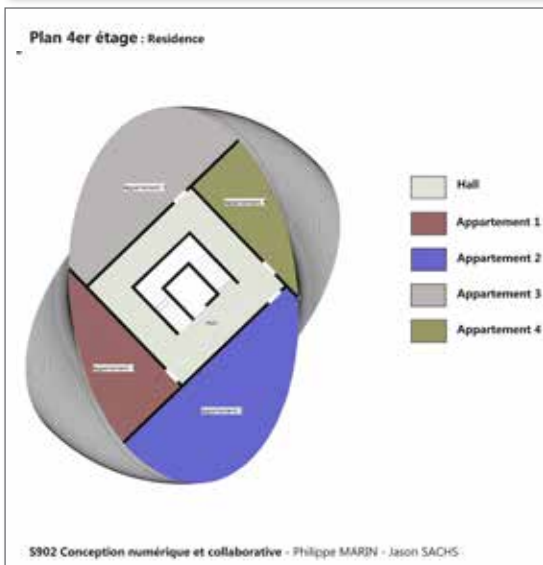
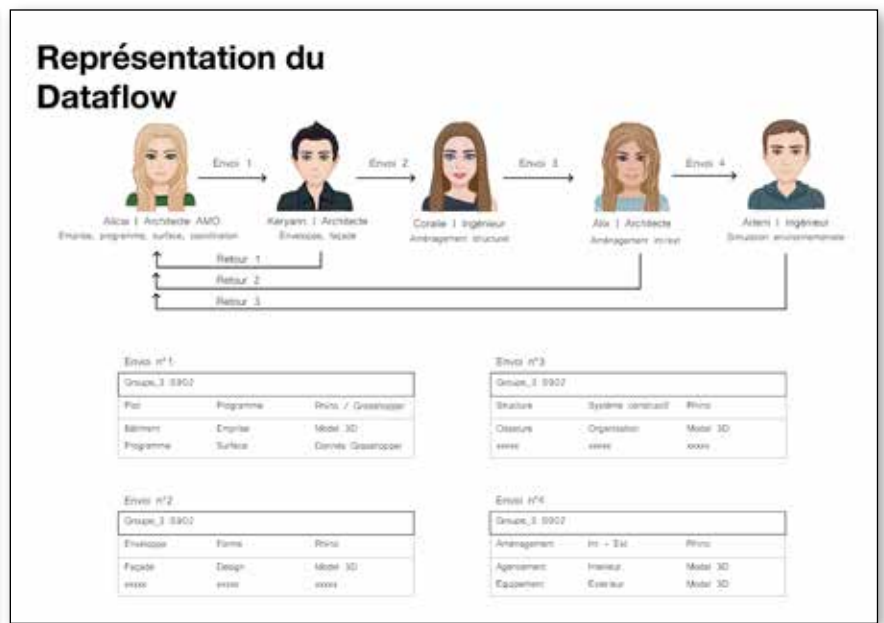
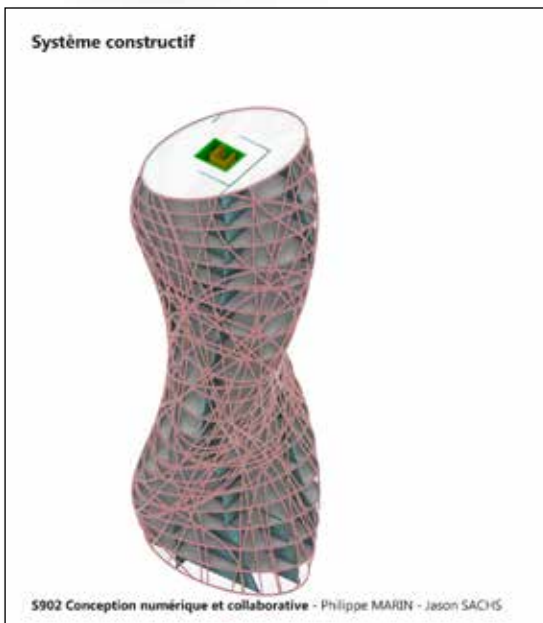

Generative Design Interfaces :

Using this approach to both analyze existing projects and conceive new tectonics!



Construction Project Analytic modeling and drawing
OPUS Hong Kong, Gehry by Coralie RICHEBOIS
Studio S5AA 23 Shin Sachs

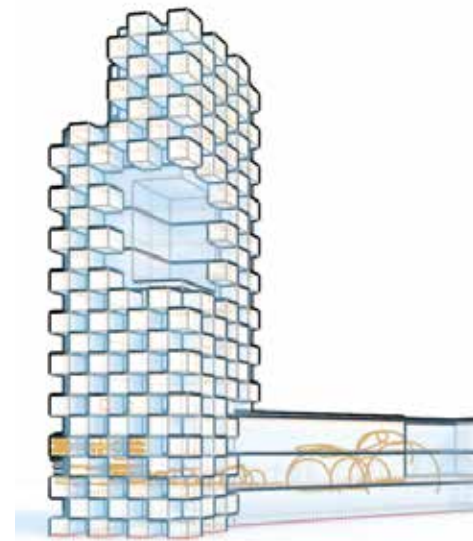
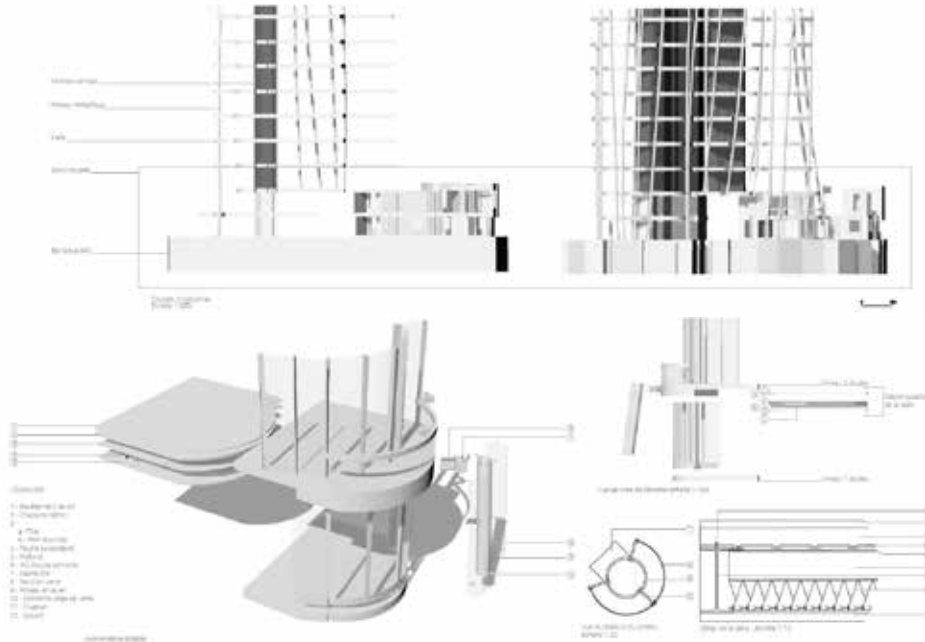

Generative Design is the base for this exploration. The model is composed from simple volumetric forms and articulated by algorithm based processes. This keeps it adaptable and agile to make changes.

Relatively simple algo based processes can create complex but variable results

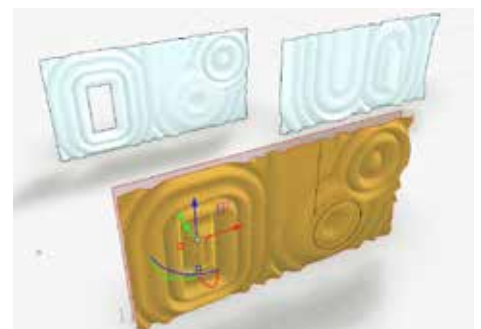
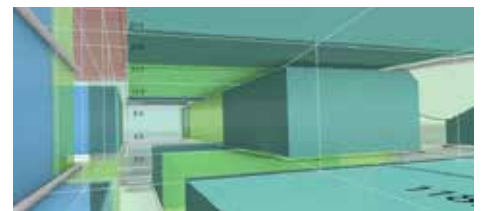
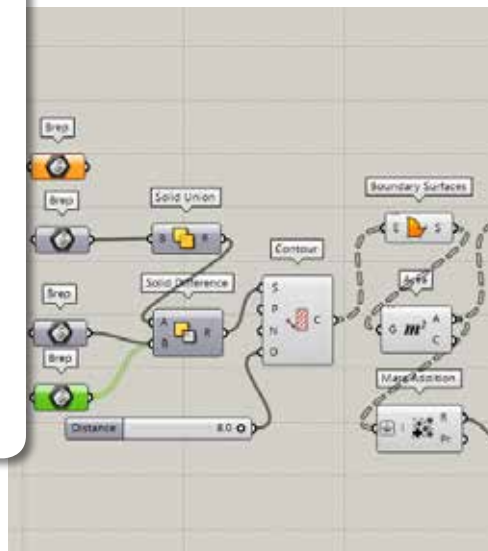

Students Fabrication and Installation : Conceiving and installing Cloud Shell Grenoble

Third year project studio Adaptive Urbanism Theme : Installation of a 1/4 scale mockup in the courtyard of the 16th century building. The former parliament of Dauphiné. Exposition : DNA Grenoble 2018



1.5



Development of faces

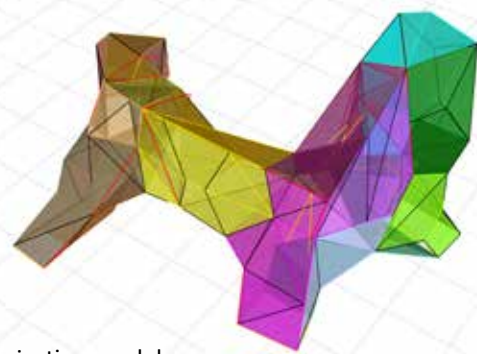

fabrication model



S60T : Urban Ecology :

Adaptation :Biomimicry :Materiality :Embodied Energy

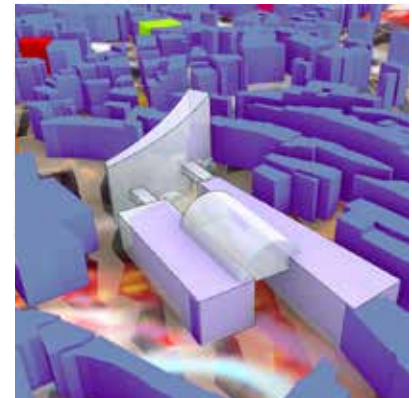
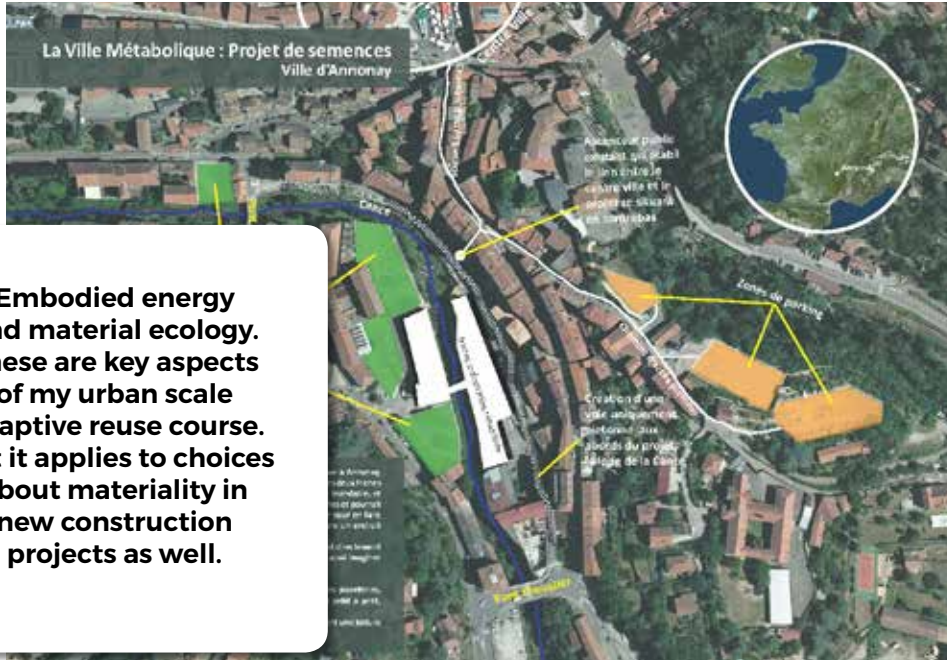

Embodied energy and material ecology. These are key aspects of my urban scale adaptive reuse course. But it applies to choices about materiality in new construction projects as well.

Meta City Seed Project, Annonay France 2022, GUIJARO FRUTOSO GIRAUD

BIOMIMÉTISME DE FORME

Obtenir une structure la plus efficace possible avec le moins de matière utilisée, flexible,

Ex : Complexe architectural du stade de Munich, par Frei Otto, inspiration toile d'araignée pour la souplesse, résistance et grande distance et ailes de libellules pour leur solidité (bcp de segments)

Ex : Canada's Royan Marquet à Royan par Eugène Tsui, inspiré d'un coquillage Bénédicte : poids léger mais ultra résistant à de fortes pressions



Complexe architectural du stade de Munich, par Frei Otto,

BIOMIMÉTISME DE PROCESSUS :

Reproduire un processus observé dans la nature afin d'optimiser le bâtiment

Ex : Council House 2- Melbourne, Mick Pearce, DesignInc : bâtiment le plus économe en énergie au monde. Cheminées sur le toit pour permettre d'ouvrir « le sommet du monticule » : inspiration des nids de termites qui régulent la température intérieure quels que soit les amplitudes de températures extérieures. Si le sommet du monticule est fermé, il se produit un phénomène appelé « flux thermosiphon » qui est en fait une aspiration de la chaleur interne vers l'extérieur par les différentes galeries creusées. Ainsi, de l'air plus frais redescend vers le nid. Si la partie supérieure est ouverte, un système passif prend alors le relais, c'est l'effet Venturi. C'est un système comparable à celui du tirage thermique pour un bâtiment. L'ouverture supérieure permet à l'air chaud de remonter et de s'échapper de la termitière, tandis que des ouvertures à la base vont aspirer de l'air frais extérieur, ce qui est causé par la dépression provoquée par la chaleur s'échappant du haut.

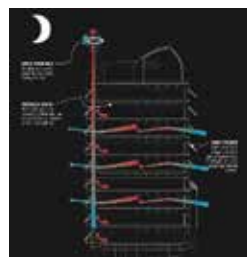

BIOMIMÉTISME DE LA PEAU :

The students observations from these studies are in French but they are examples of their research into biomimicry in form and materiality



The influence of some of my professional experience

The Spire project of Calatrava, unfinished.

My professional experience grounds me in need for and cohesion of all these aspects, in teaching young architects

In the end of this introduction I include just a snapshot of my professional work and also research, design and just creative endeavors. These are example of the experiences that inform and inspire me that I infuse into my teaching.

I come to this approach to teaching conception through models and detail development of systems from many years of project leadership both on conventional and very complex project like this one. Developing detailed 3D models addressing the design and coordination piece by piece. And with teams of excellent professionals in all disciplines.

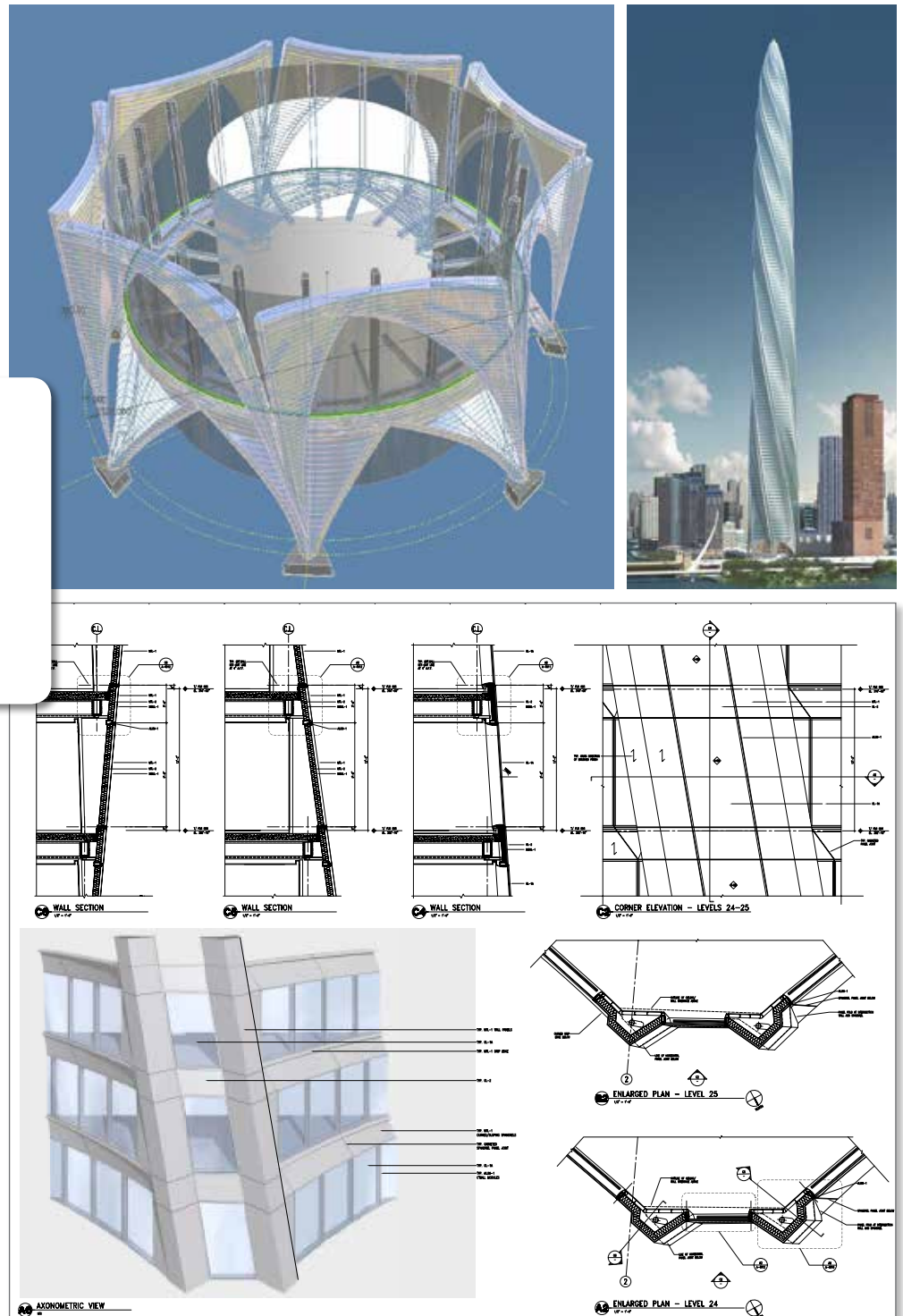

The Chicago Spire, Project of Calatrava

Models: Visualizing Volumetrically: Sketching & Drawing

Student Study Models, My Models

Casa Malaparte:
Libera / Malaparte
by Indra COUPIN
ensaG 2018

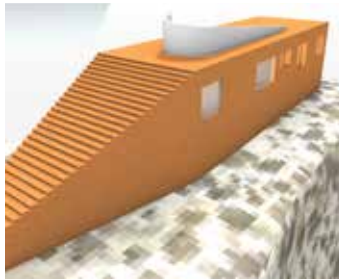

IAC Building:
Gehry Partners
by Veronika DESOVA
ensaPLV 2016

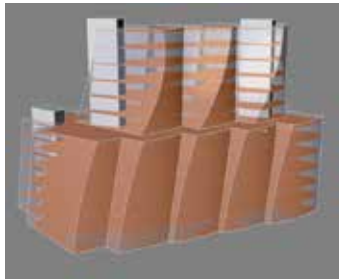

Broad Museum:
DSR
by Lisa SAMPER
ensaG 2021

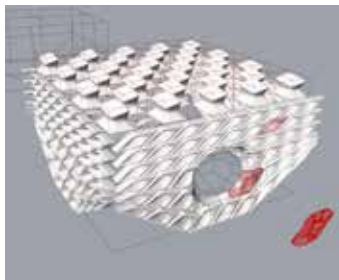

Graz Kunsthaus:
Peter Cook
by Abba BEN EL
MAMOUNE ensaPLV 2016

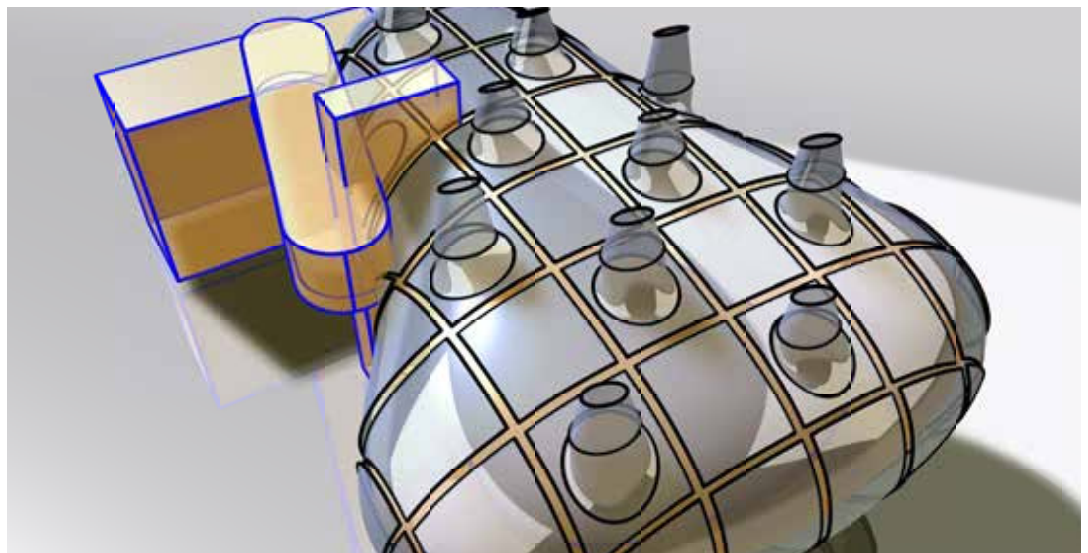



Detail model and fabrication preparation for the recovery and preservation of a historic project of French 1960's experimental architecture. In exhibition at Conseil d'Architecture Urbanism et Environnement de Haute Savoie, (CAUE74) Annency Fr. March 2020

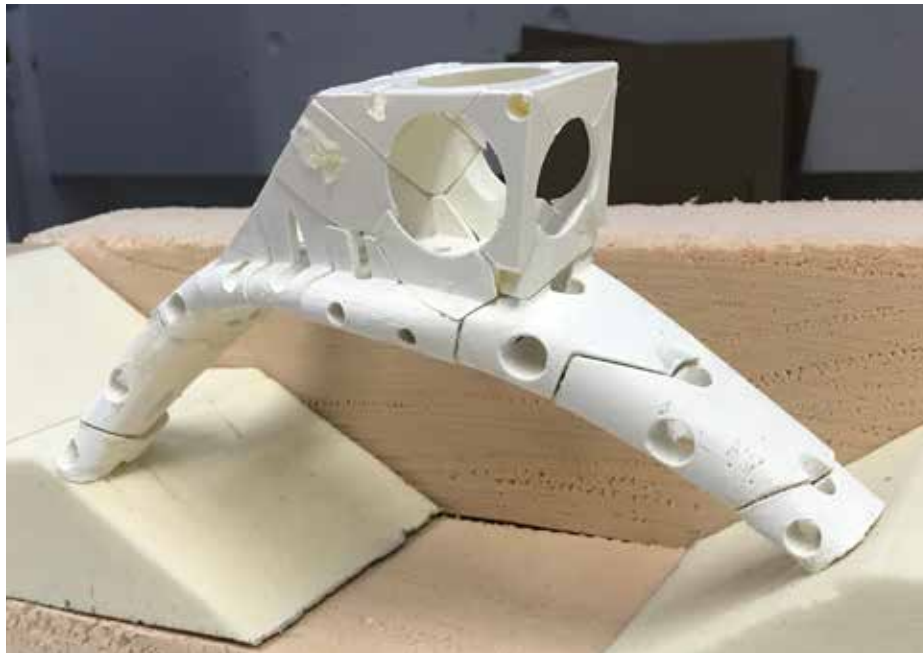

First Study model in cellular architectural scale 3D Printing: IDEX Funded Research Grant Directed by Grenoble INP & Maison De L'Architecture de L'Isère; Project: "The Cloudshell Derivations Cloud Shell Isère " Subject of research 3D Printing of building scale vaulted vousoir structures - 2019

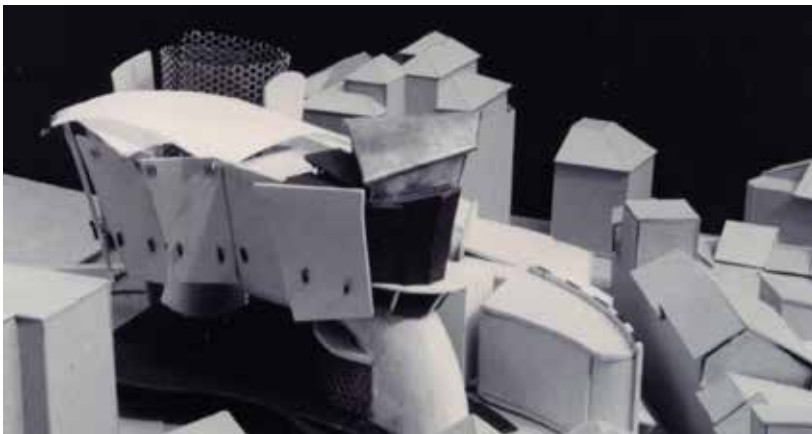

Rome Studio project model , UIC 1994
Direction Doug Garofalo



Spertus Institute:
Finalist Chicago
Architecture Club
Burnham Prize
Competition 2001
Exhibition at Gallery
400 at UIC 2003

ENSAG S6AX : Workshop Brutalist Façades

shading studies in drawings and mockups, 2022

Looking at the work of the brutalist architectures for inspiration, with their abstract geometric forms replicated on façades to create sculptural compositions; we will study all things related to the effects of shading on façades and the elements that create them.

We will construct mock-ups of building facades at reduced scale and conceive patterns of brise soleils and other shading elements, to experience the effect of design and composition of solid : void / chiaro : oscuro on façades.

We will start with sketching and drawing for idea development, chiaro oscuro techniques with charcoal on paper.

We will construct physical mock-ups of multiple variations with paper and cardboard at 1/5 scale, with hand fabrication.

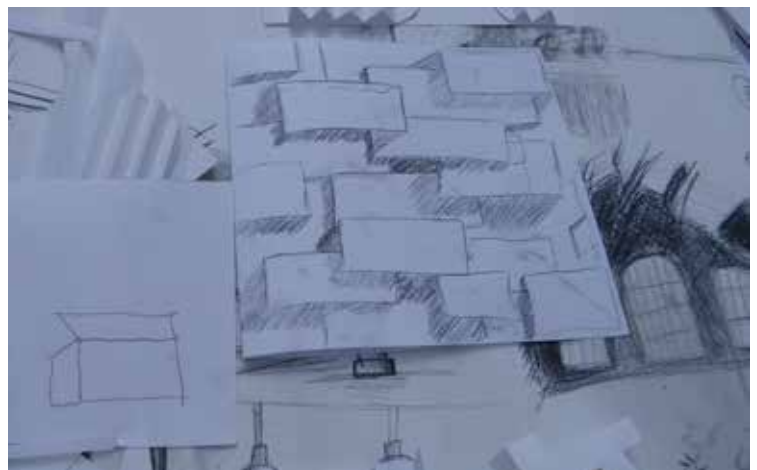
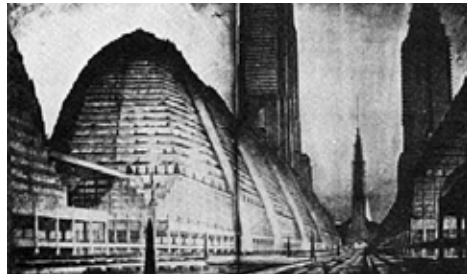



Finally we will study and document the results with photographic studies in high contrast black-and-white. At the end, we might add some algorithmic tools to see how the physical mock-up results compare with simulations. The simulations may provide another layer of graphic contents to add to the imagery created.

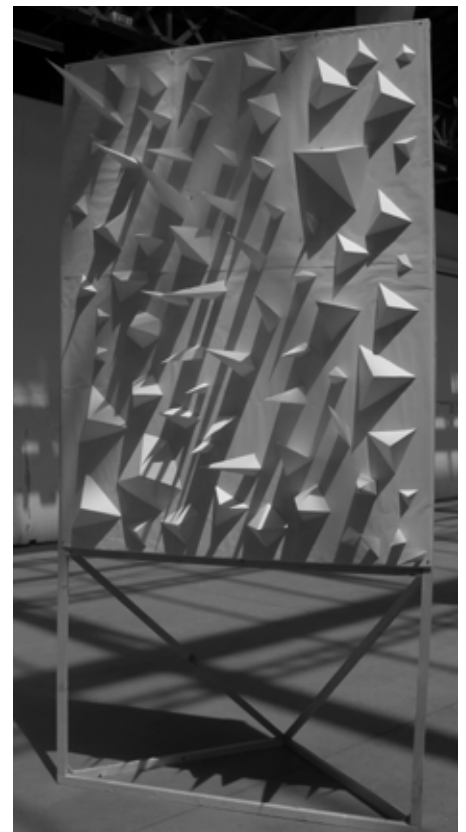
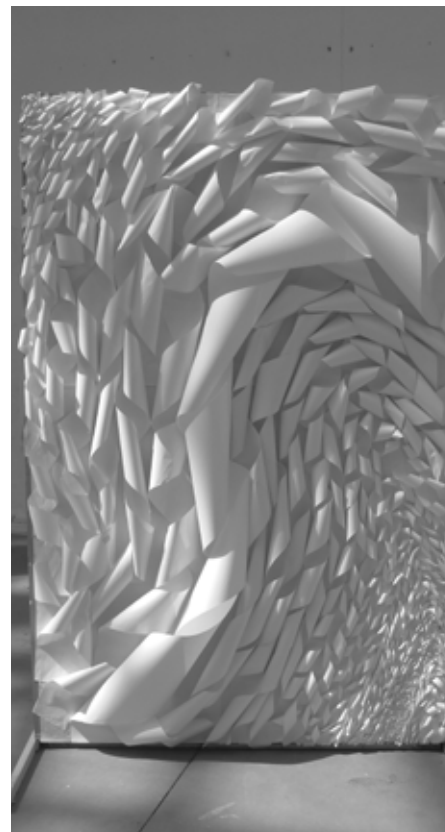

ENSAG S7CT 21: Student reconstruction model of an unbuilt project, Jérémy Chotard, 2021

The re-modelization of an unbuilt project. Learning BIM and construction

Wagner residence
Frank Gehry
Malibu, 1978
unrealized

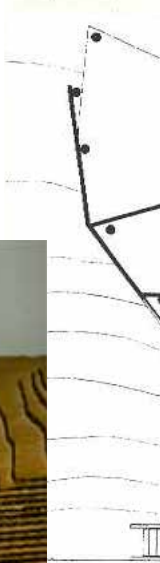

Original hand sketches and models Wagner house

WAGNER HOUSE

La modélisation BIM à l'aide de Rhino et VisualARQ est un bon moyen de s'affranchir de Revit ou ArchiCAD mais son utilisation ne se relève pas aussi facile. C'est un outil vraiment intéressant permettant de faciliter des tâches au sein de Rhino mais en complexifiant d'autres par la même occasion. VisualARQ est facile à prendre en main, toutefois, sa gestion des fenêtres rend très compliqué la mise en place d'ouverture dans les murs, même à l'aide de courbes. Par ailleurs, la jonction des murs devient très ardue si le mur n'est pas orthogonal, on perd l'aspect vernaculaire qu'offrirait Rhino. Enfin l'utilisation des courbes et des surfaces oblige à bien agencer ses casques car ils peuvent gêner la conception comme le rendu de la maquette, c'est un aspect à prendre en compte.

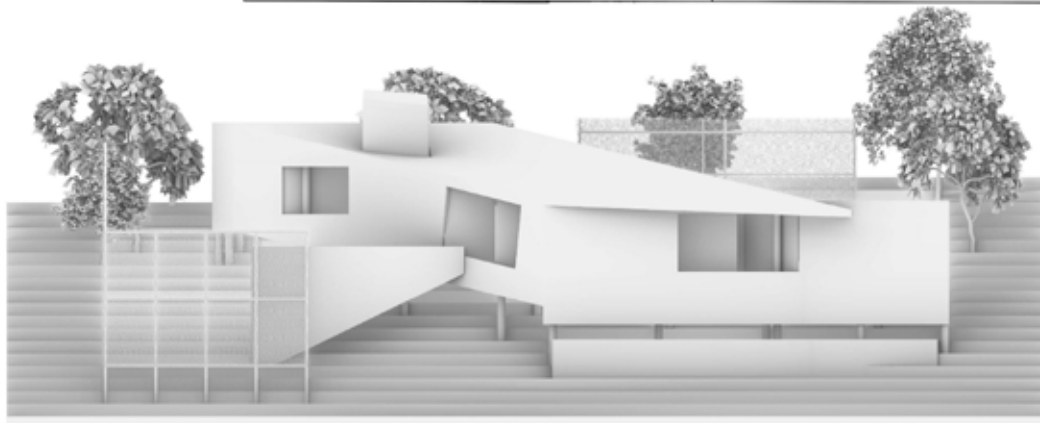
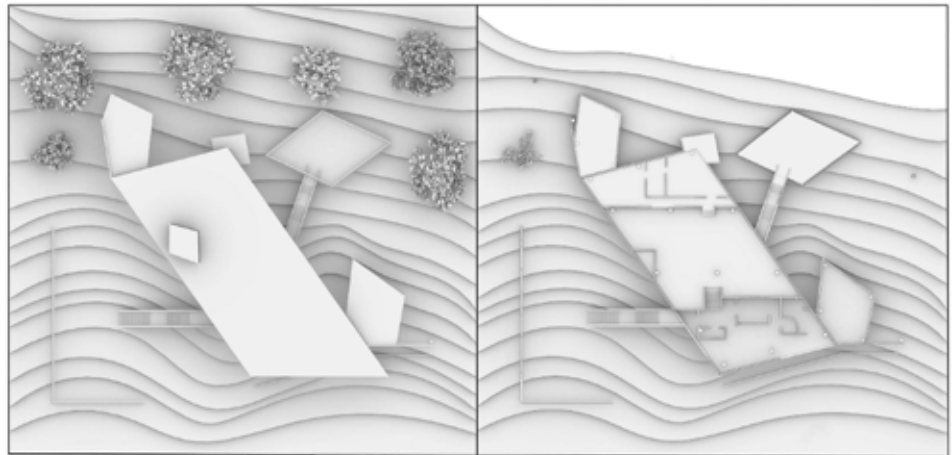

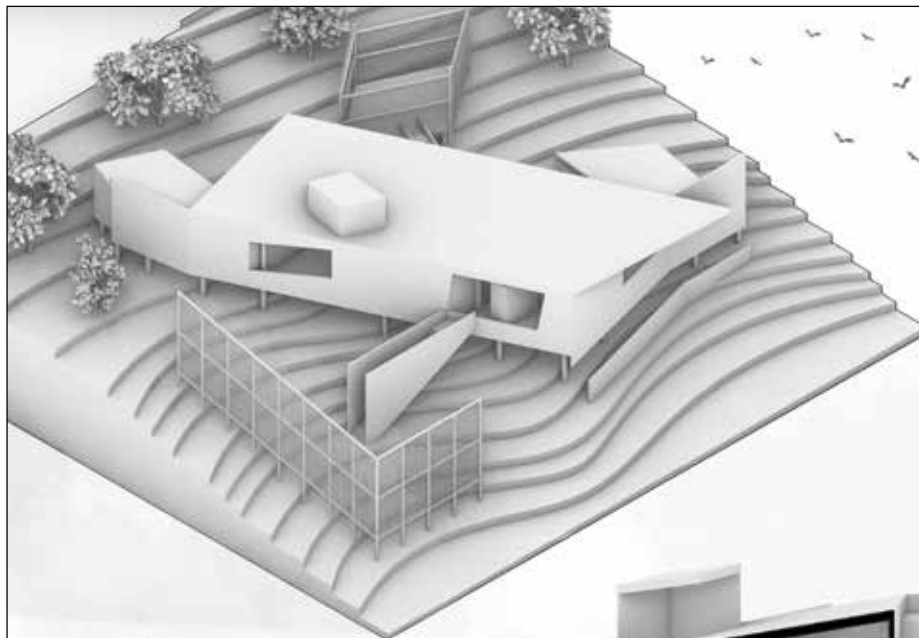
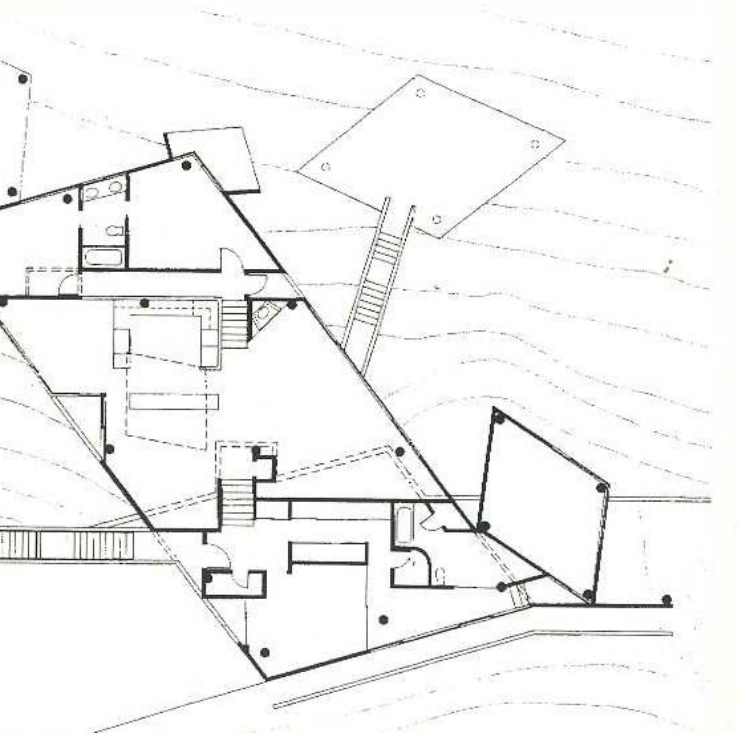

WAGNER HOUSE

Les entrées sont marquées par des vides marquant le parallélisme du terrain. Des écrans de protections solaire en treillis métalliques donne au visiteur l'impression qu'un glissement de terrain pourrait se produire à tout moment. Le parking se dote de tapis d'asphalte sculpturaux et accentue le décalage.

Enfin, il faut savoir que la maison est devenu très célèbres suit à l'exposition sur la « déconstruction » organisée par Jeffrey Jipnis et Philip Johnson au musée d'Art moderne. Sans rapport avec Frank, ils avaient choisi cette maison comme exemple parfait de déconstruction architecturale, notamment grâce aux poutres en porte-à-faux. L'étanchéité a été un problème majeur. Bien qu'imaginée en 1978, celle-ci n'a jamais été réalisée.



Drawing Descriptive Geometry

L 37, ENSA Paris La Villette, 2016

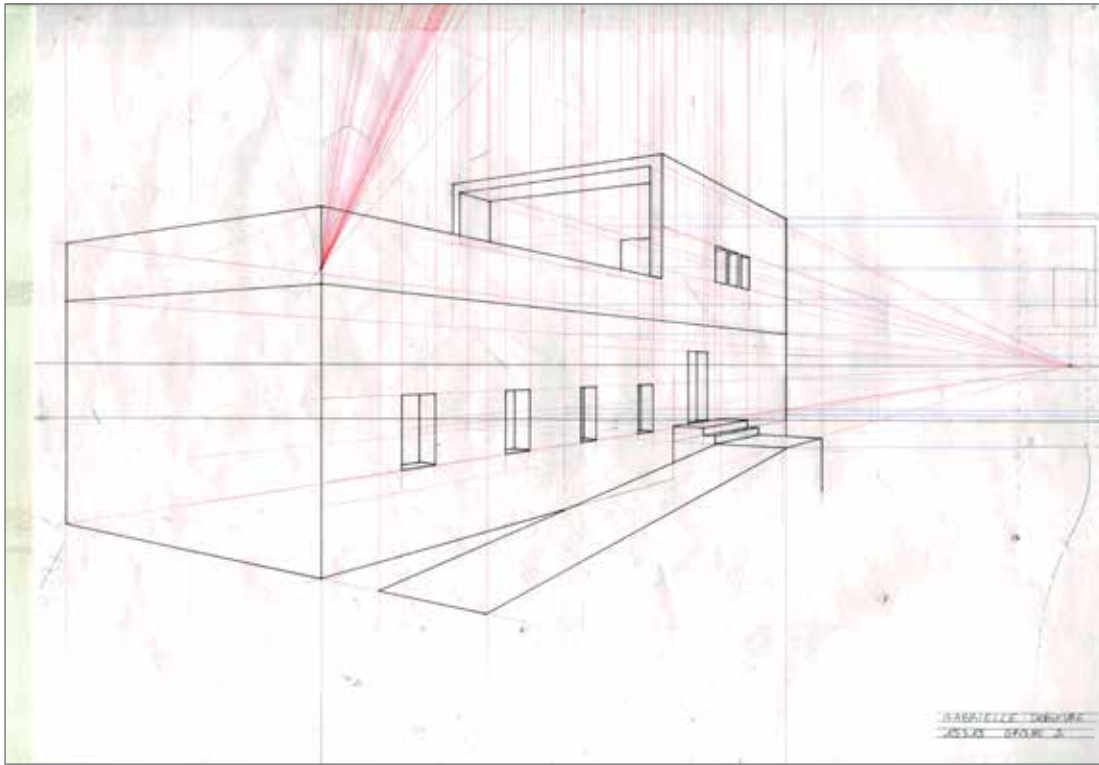

Studies in construction of perspective and axonometry by descriptive geometry drawing methods taught in the traditional Ecole De Beaux Arts methods.

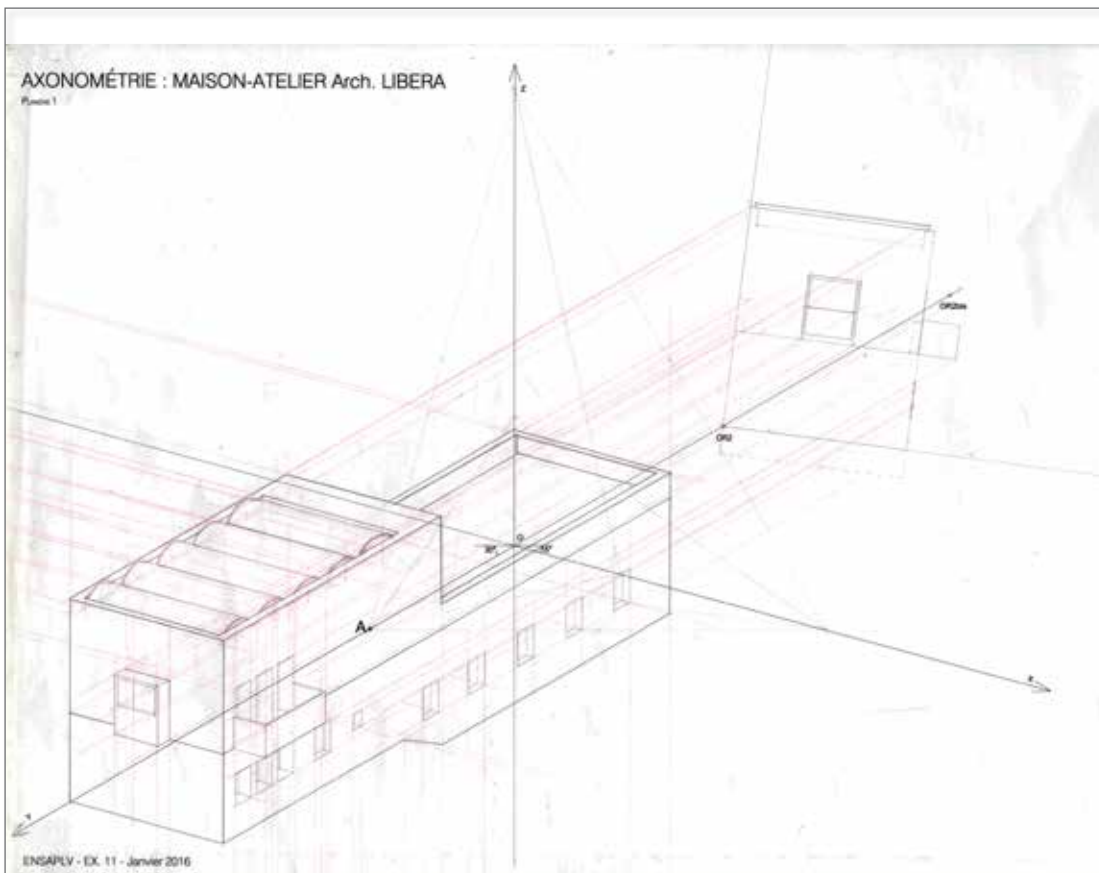

S7CT Generative AI: Speculative Urban Renders

Hacking
Grenoble



Hacking
Paris



Projects Studio

Bern Concept Studio Spring 15, with Julie Flohr

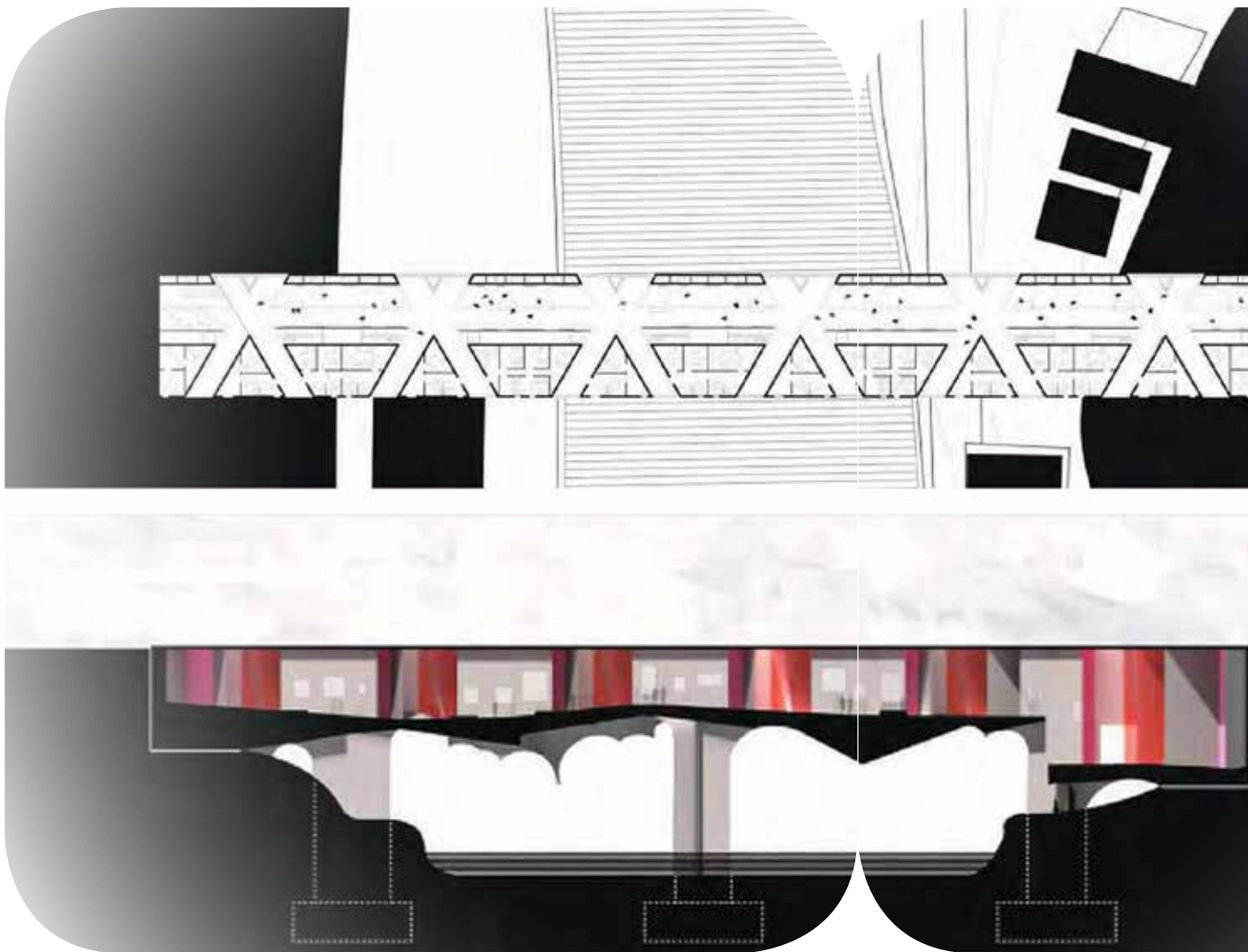

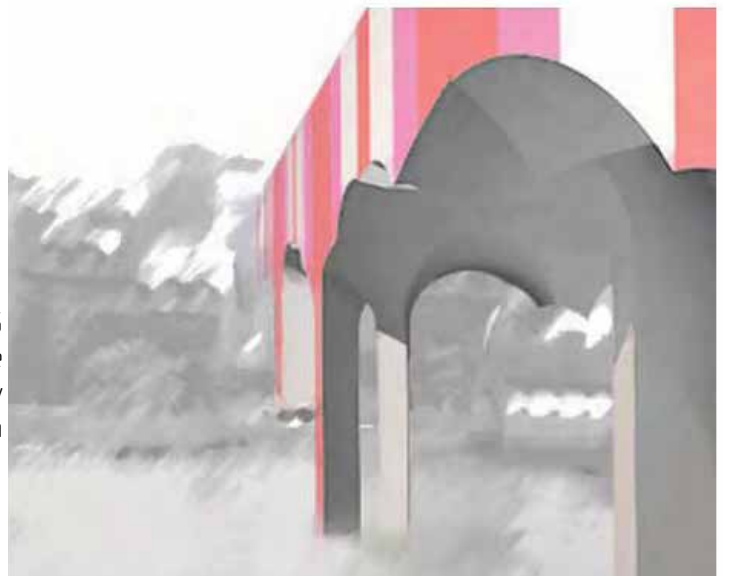
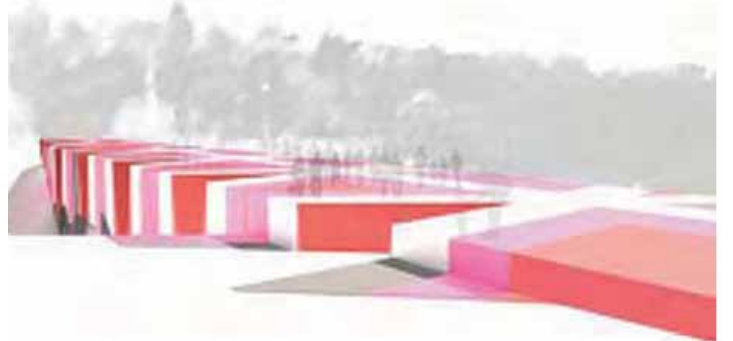
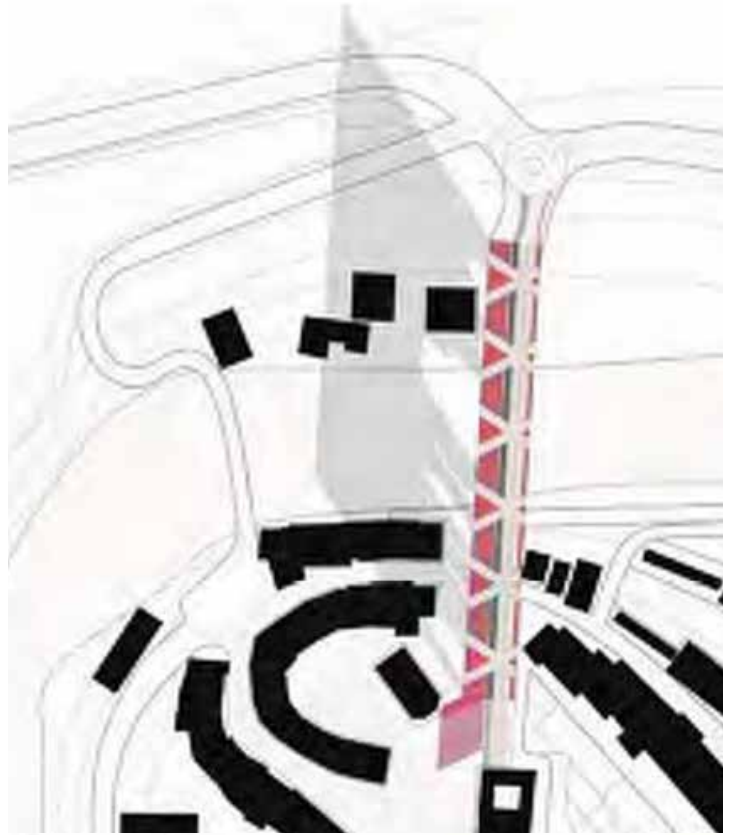
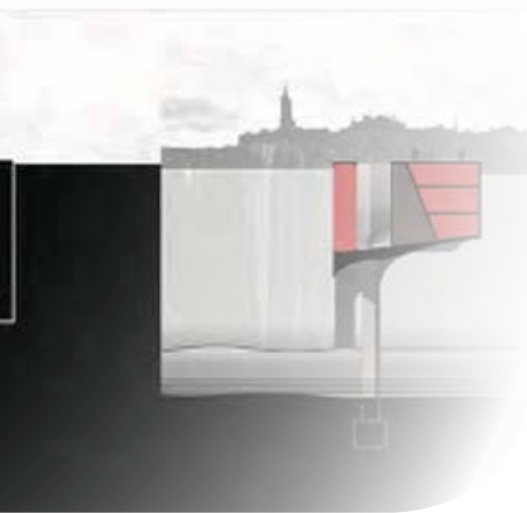

3rd Year Project Studio Spring 15
Bern Bridge Site
DOS SANTOS FARIAS Eva Joy
FERRERE Lysa

Projects Studio

Voiron Vicat Concrete Factory Site Fall 22 with Tchely SHIN

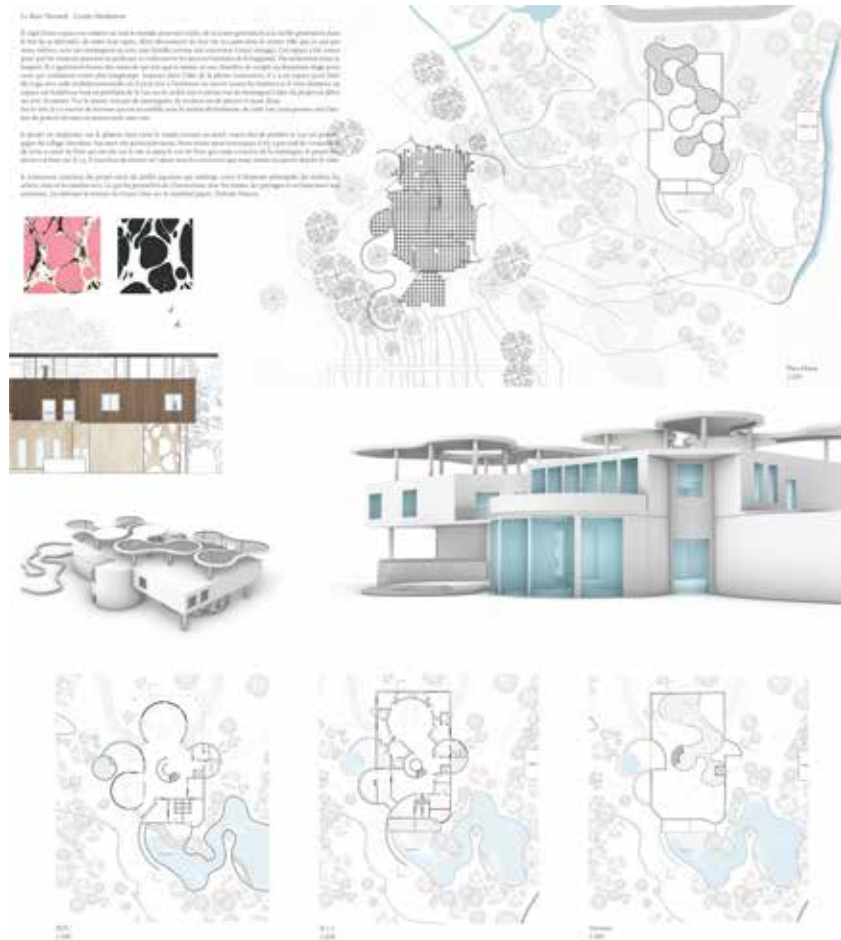

3rd Year Project Studio Spring 2022
PUTRI Catlea



Mon projet est un centre thermal implantée sur le plateau haut entre le masif orientée au nord-ouest afin de profiter la vue un peu décaler du village chevalon. L'idée du projet est d'être un avec la nature. Vue le site est entouré de montagnes, de rochers ou de pierres et aussi d'eau. Cette maison de bain sera un endroit où tout le monde peut visiter, de la jeune génération à la vieille génération dans le but de se détendre, de vider leur esprit, d'être déconnecté de leur vie occupée dans la ville que ce soit par nous-mêmes, avec un compagnon ou avec une famille comme une excursion (court voyage).

le traitement paysager du projet viens de la maison de bain traditionnelle japonaise "Onsen"

le traitement extérieur du projet également basé sur le jardin japonais qui mélange entre 4 éléments principale, les roches, les arbres, l'eau et les jardins secs Ce qui lui permettra de s'harmoniser avec les routes, les paysages et architectures aux alentours.

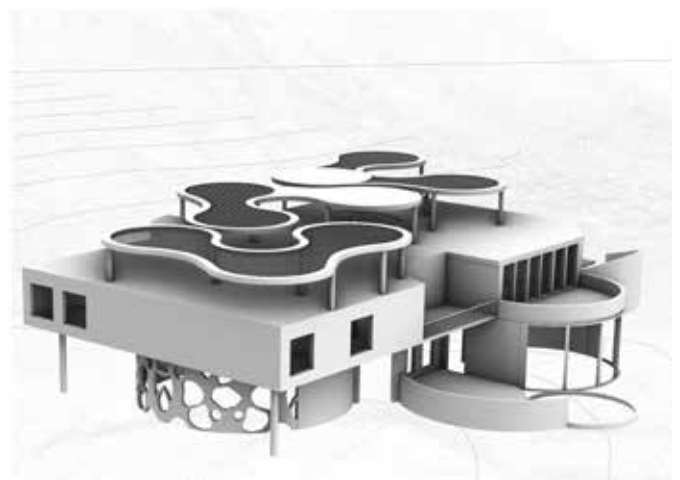

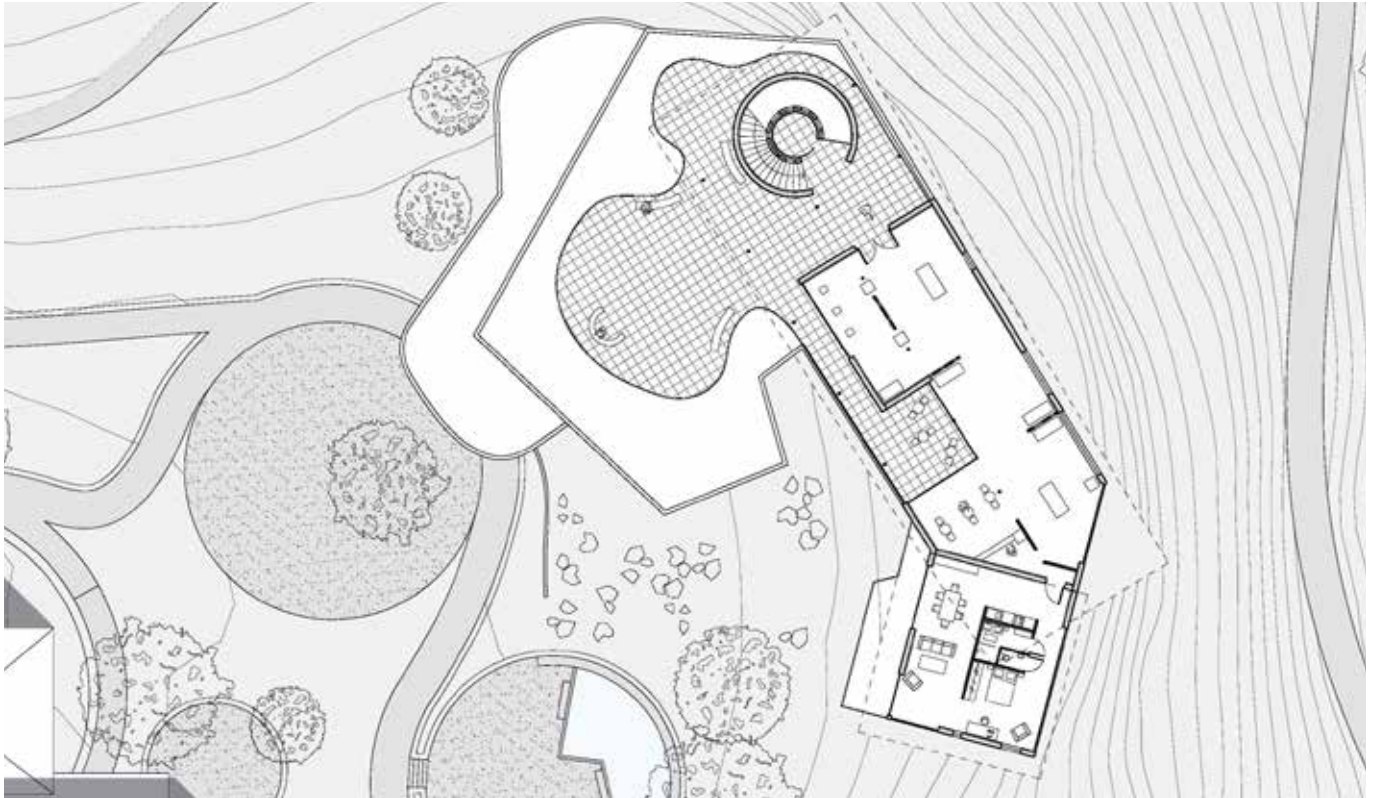

3rd Year Project Studio Spring 2022
CHAVANNE Jordan

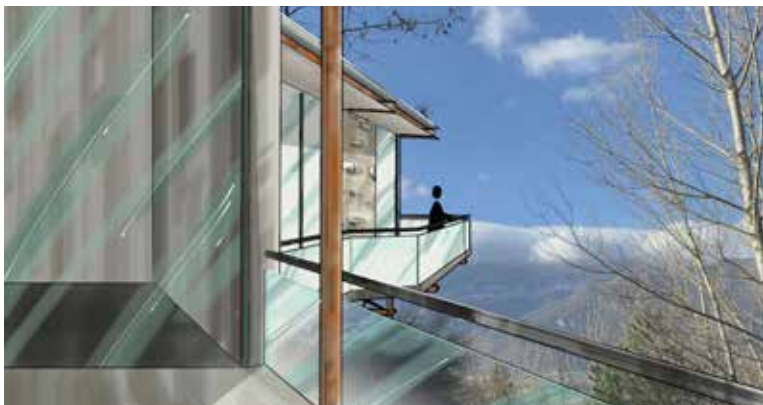
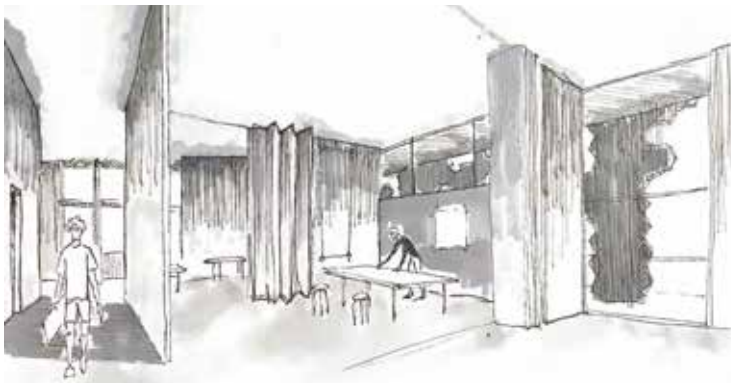

Projects Studio

Basel Bernoulli Silo Decomposition
Concept Studio Spring 15, with Julie Flohr

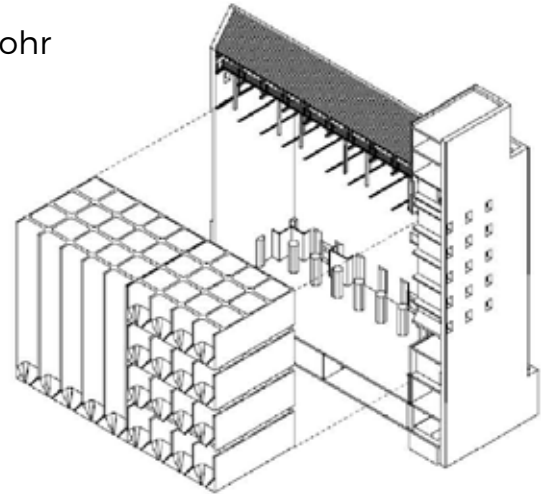

Analytic model of
imposed stresses on
deconstructed silo

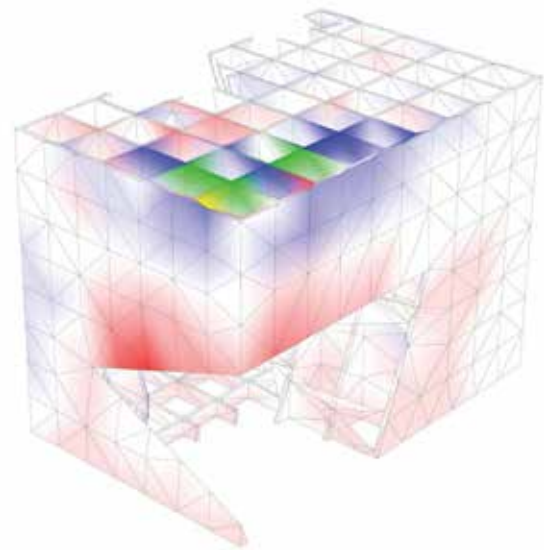

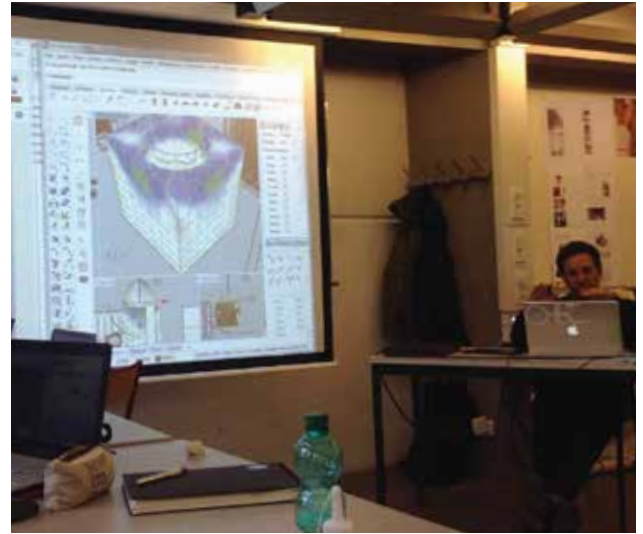
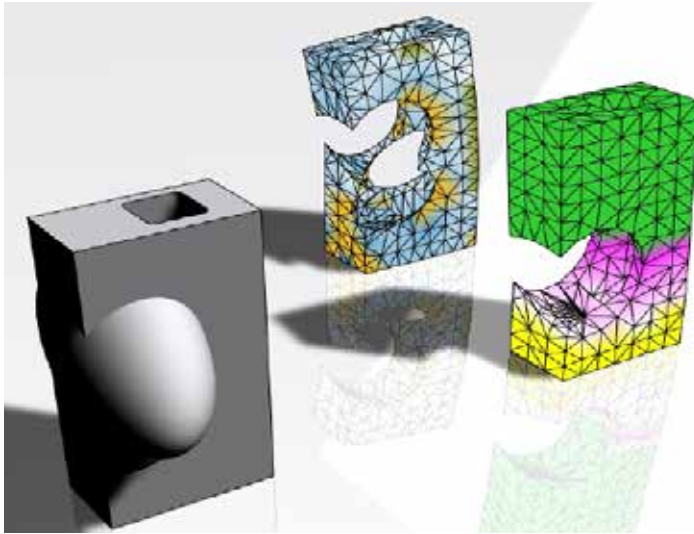

teaching the Karamba based analysis

3rd Year Project Studio Fall 2017
DEMERYZE Melanie



Tectonics & Structure Fabrication

Adaptive Urbanism Project Studio

Fall 2018, with Julie Flohr

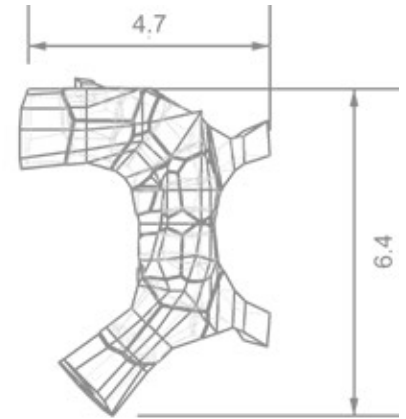

Third year project studio Adaptive Urbanism Theme :

Installation Parc De La Villette Paris : At conference FAB 14 Paris

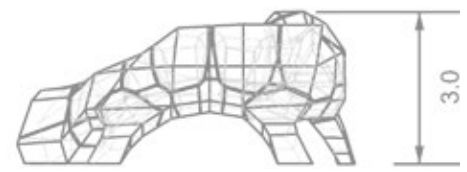



Composed Fantomes : Urban Interventions



3rd Year Project Studio
Fall 2018
JABBOUR Miguel



3rd Year Project Studio
Fall 2018
FORQUE Elise

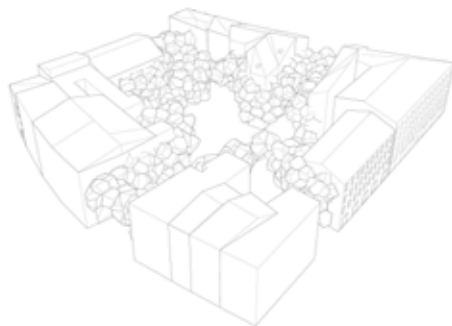

Tea cup modeling

an introduction to variable modeling

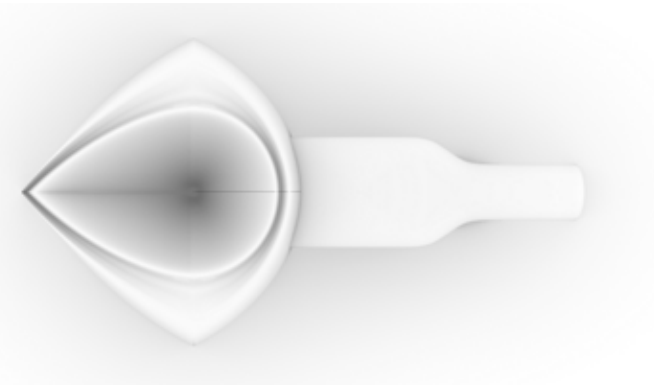

Tea cup modeling with control geometry history, exercise rendered in multiple courses as an introduction to variable modeling.

Exercise in modeling tea cups, with the geometric history of creation protected, makes design variation possible. Each student develops their own design in less than an hour. The result is that each has a unique design. The model is simple, but it involves each student engaging directly with/engaging directly with the object. And by the end of the exercise, each cup is ready for 3D printing. This underscores the strong advantage of this design approach. The path is direct to manufacturing.



Résultats des élèves, à partir de plusieurs centaines d'exemples
Impressions 3D des modèles

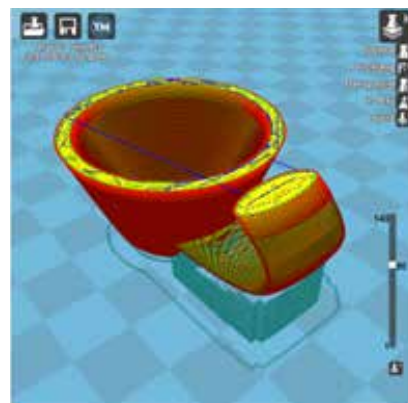
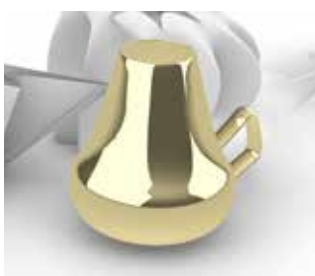

Project Furniture: Design Program DPEA, ensaG

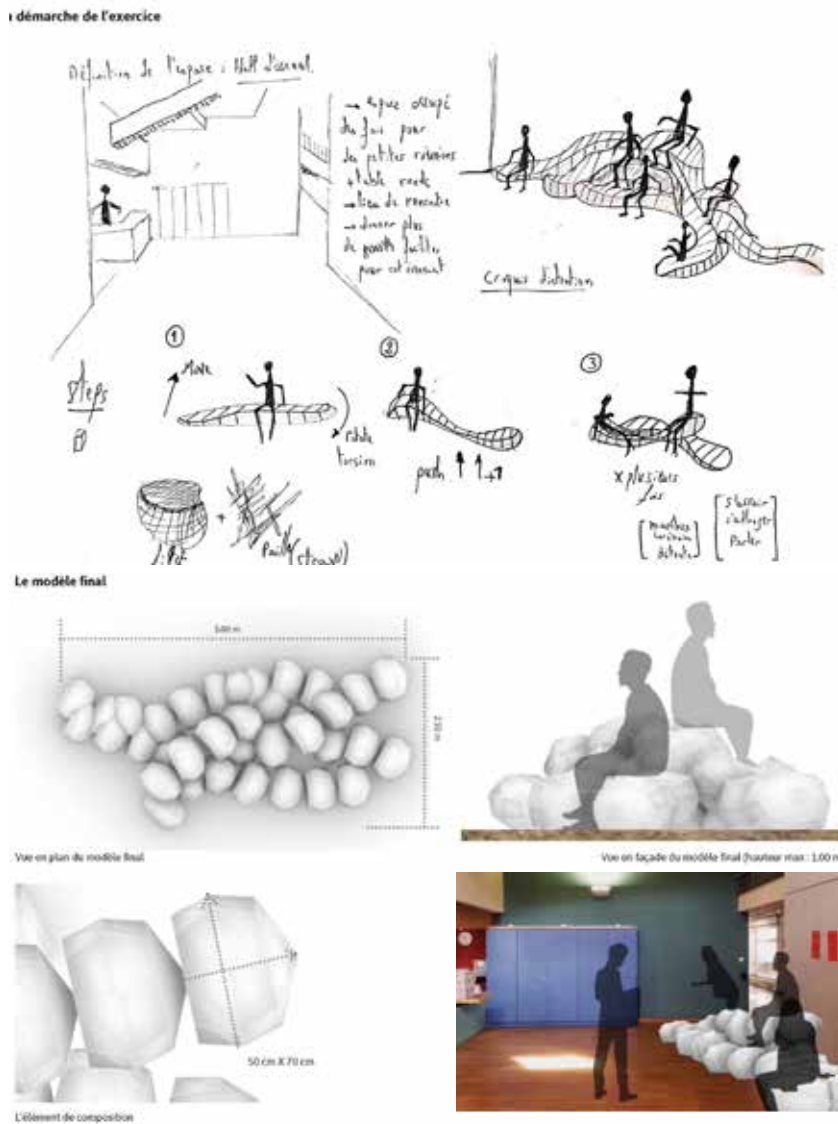

Using physics simulation of gravity and “digital touch” to create instances of design pieces.
Marouen HAMMAMI, 2020

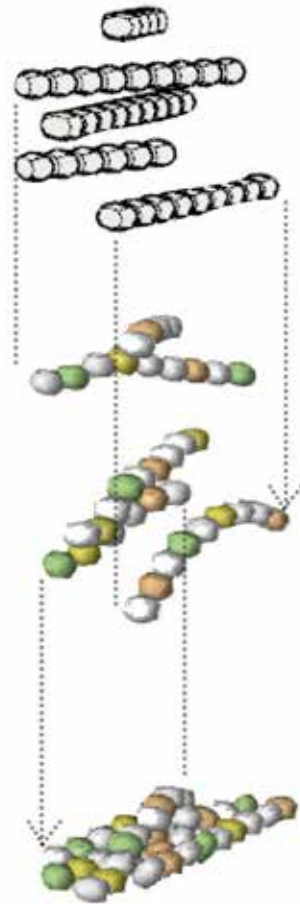

Sophie MERIGNY, 2017



Damien DUFOURNET, 2020



Thao Vy NGUYEN, 2020

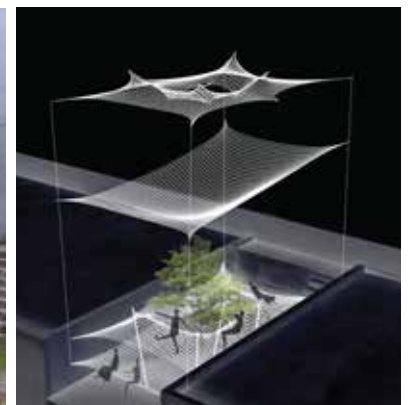

Cartography : Urban Systems : Ecology

an introduction to variable modeling

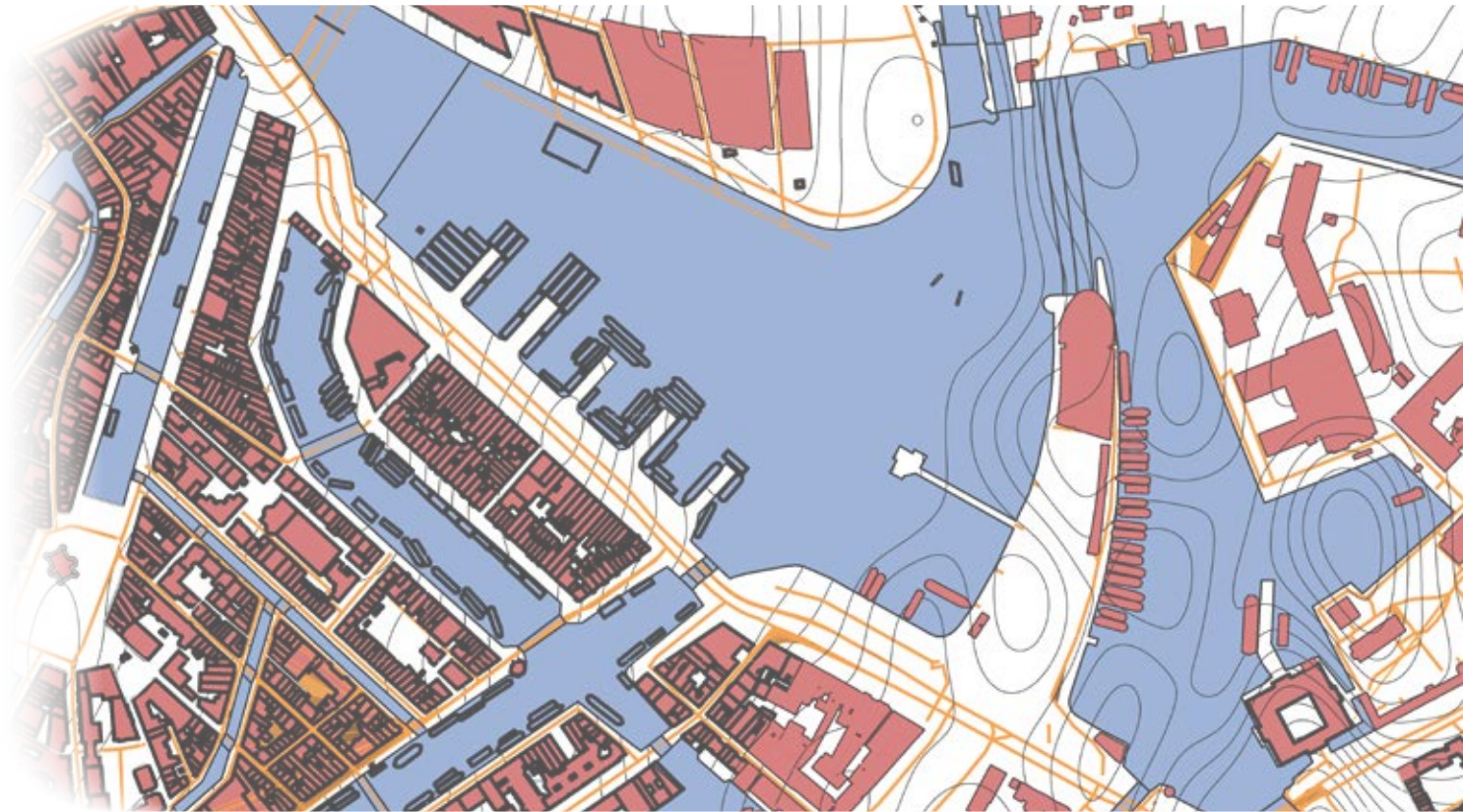

2D Topographic Study Map : Generated entirely from open source data : Amsterdam



Invisible Cities Exhibition, 2003
w/ Brininstool & Lynch

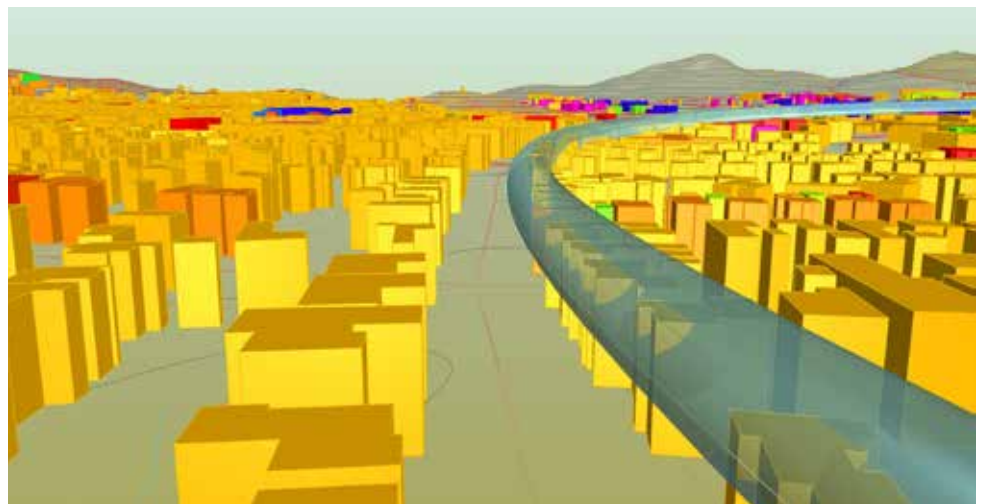

3D Topographic Study Map : Generated entirely from open source data.
First concept maap for SLO LOOP

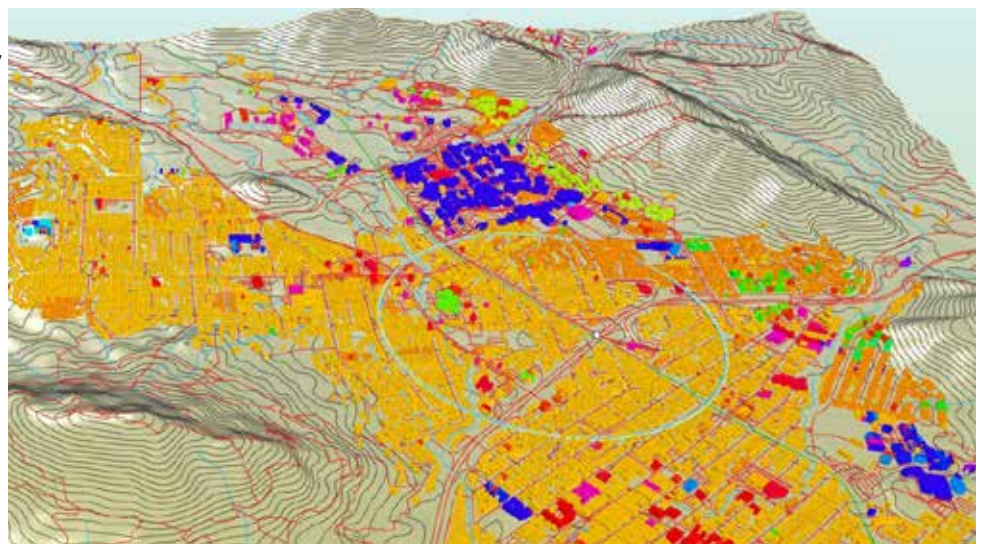

S60T : Urban Ecology, Form, Function and the Metabolic : Circularity in Architecture. Or Where To Land In Architectural Practice In Anthropocene?

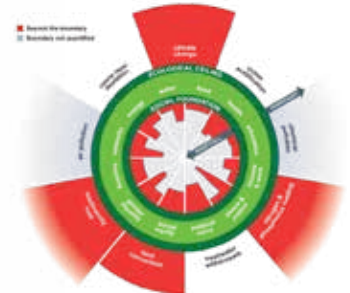

Meta City Seed Project, Lille France 2022, PELLETIER FRATINI BOUCHE

Ultimately this is about reintegrating food water energy into the local.

There is a strong ecological focus in everything that I teach. I always express the need for integrating passive and active energy systems and simply creating microclimates and open environmental natural spaces within buildings.

This goes back to my undergraduate in Geography with a focus on urban development and environmental policy. We knew then the climate crisis was coming. At the time I was studying what we called ecological economics what today we call circularity.

This is an aspect of the Adaptive Urbanism Project informing and building on the pedagogy

OPTIONAL TRANSITIONS 2 S6 OT Urban Ecology, Form, Function and the Metabolic:

In order to raise awareness of the logic of the «circular economy» with its regenerative flows of resources, resembling the metabolic functions of a living ecosystem, students will undertake the analysis of the conditions of use of existing urban areas at the scale of the urban border. Paris / Lyon / Grenoble can provide a useful comparison of scalar organization. This scalar difference will emphasize the need for a human-scale relationship in defining boundaries. Odom's Energy flow analysis methods will be presented.

Once this understanding is gained, the Linear / Circular contradiction will be explored. The research will examine what types of uses must be reintroduced, within the «local» urban boundary, to cultivate this metabolic function. This will be followed by an analysis of existing built architectural resources and an examination of the potential for local renewable energy, food and water production, as well as local non-polluting industrial production.

Finally, adaptation strategies will be proposed to cycle resources, build resilience, and provide for the basic needs of local residents. Students will work in small teams to design an intervention with a conceptual projection of resource flows. They will identify existing buildings with the potential to be used to reintroduce productive functions. An EcoPLU plan in the form of an urban diagram will present the strategy for the areas and location of resources, within the district. A resource flow diagram will accompany this strategic plan.

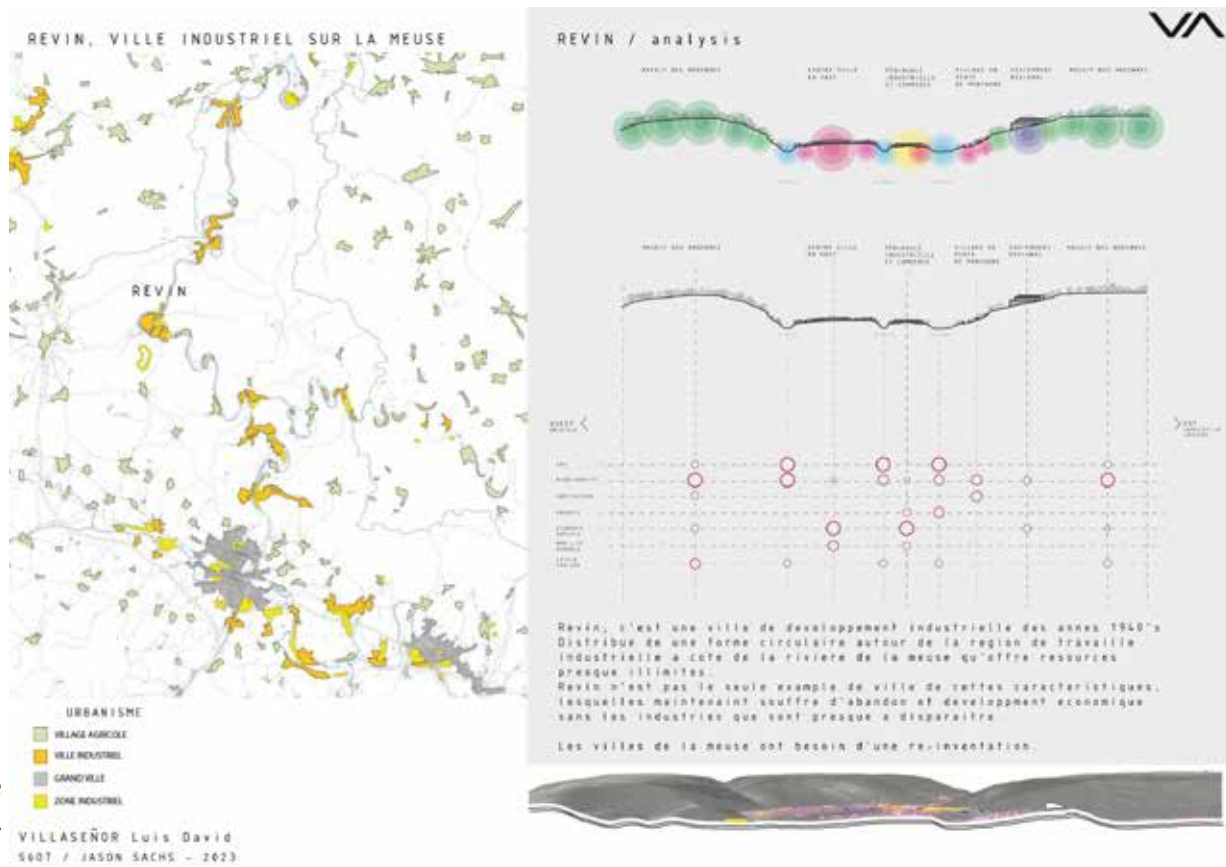

Meta City Seed
Project, Revin France
2023, VILLASEÑOR
David

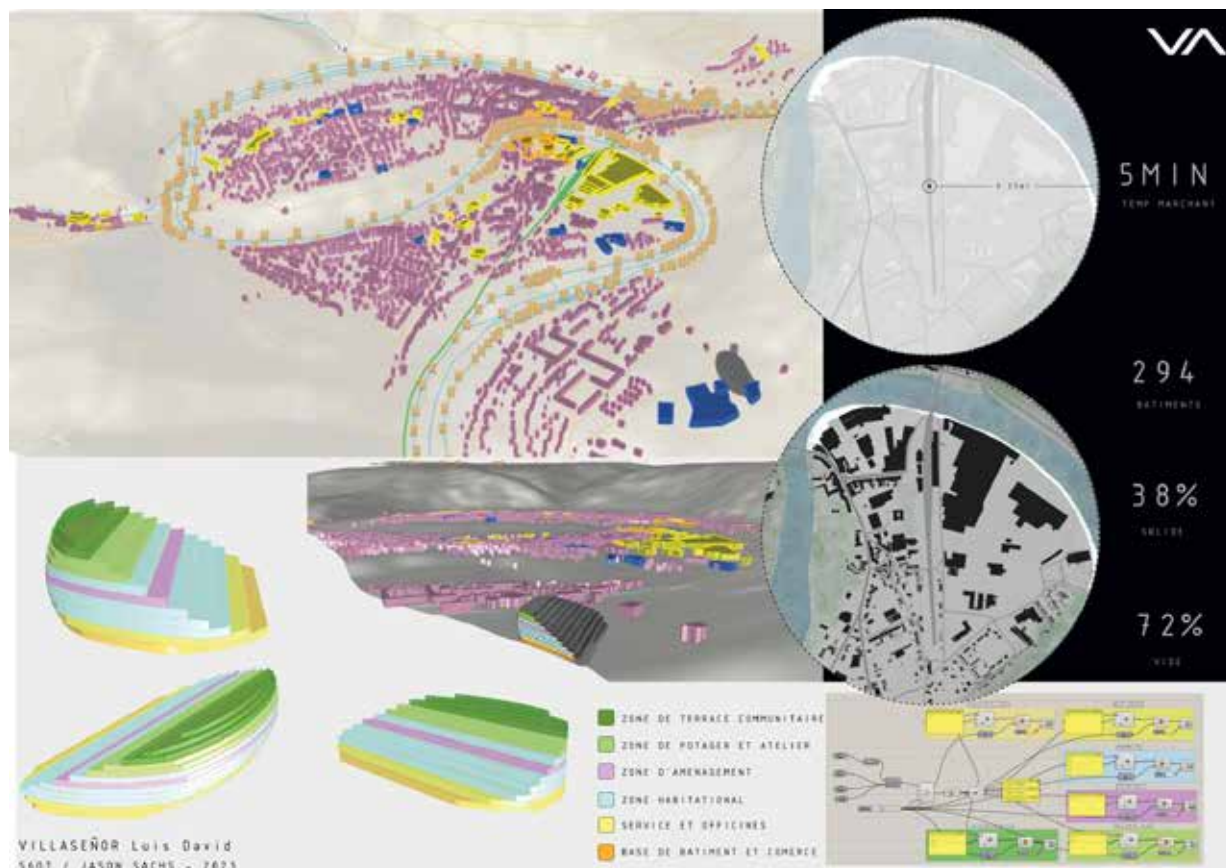

Research & Design Development:

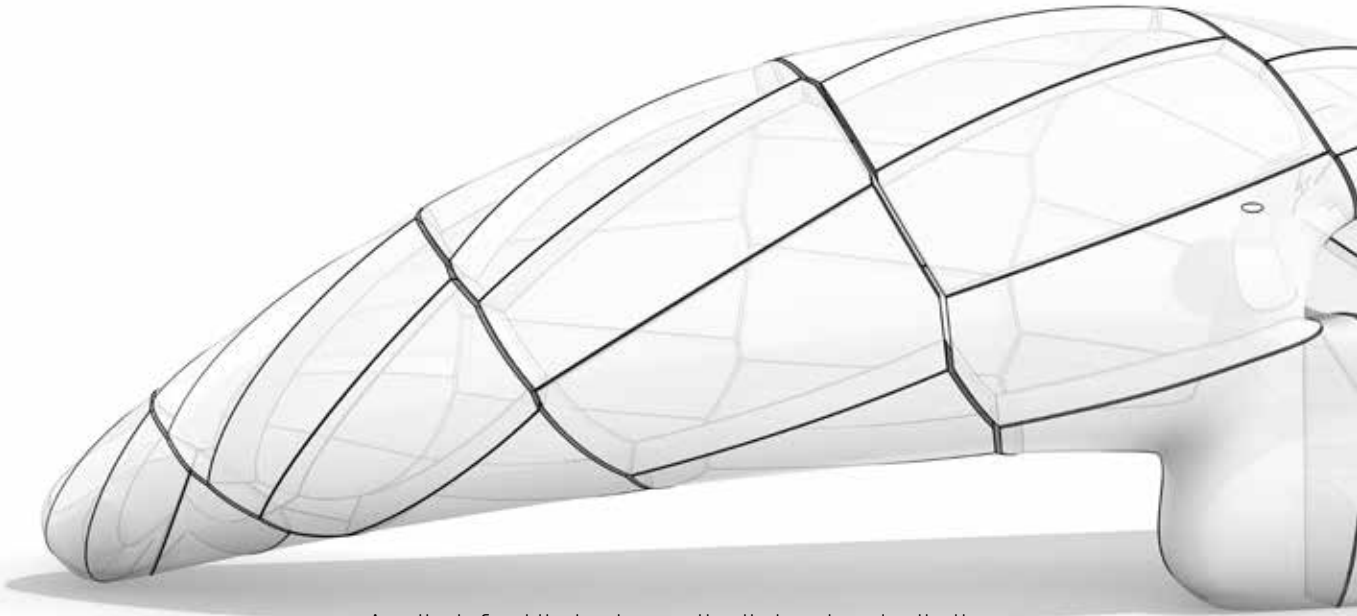

Cloud Shell Derivations: Adaptive Urbanism

A method of architectural conception that can have implications for alternative forms of spatial arrangements, much larger than building scale. It has implications for new approaches at the urban scale, a concept of Adaptive Urbanism. De-coupling interior construction (user specific) from "Core & Shell" in mixed use buildings. A mix of uses, clearly being the best approach to achieve and organic (Distributed Network) pattern of growth and development. Modularized systems of infrastructure (smart grids) could be expanded progressively along with componentized building form, and integrating and/or following transportation systems. This method would allow for need based growth as opposed to the current model of mass development.

Though it is common practice in architecture to separate the logic of the design process into these phases; it is rare that the core and shell phase is conceived of as a generic space, suited first to the site and second to a range of potential uses. Uncertainty is seen as something to be avoided in a market driven rational economic (real estate development) climate. If buildings were conceived first in a non-program specific context it would allow the design process for this phase to prioritize building flexibility, overall performance, impact on its cultural social context and priorities of urban density. This proposed approach may prove to be a model available in the near term, to facilitate the construction of a more robust and sustainable urban fabric.

Development of day1 bim Tools:

A concept generative design front end for architects

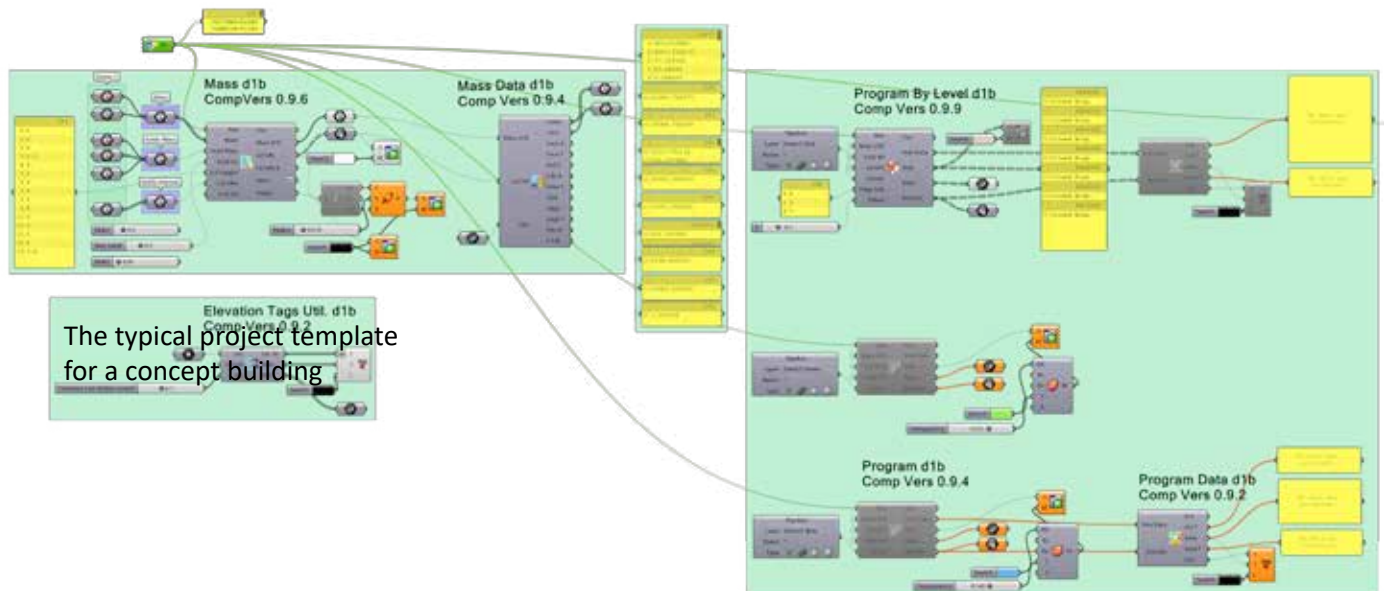

day1bim Tools is a set of conceptual massing and programming tools for architects, which allows the user to quickly develop a project concept model and extract fundamental project information. The concept model developed can be used for simulations and representations. With grasshopper based connections, the geometry can be linked forward to generate native elements in a BIM environment. It's a flexible model that is ready to visualize in minutes and easy to modify.

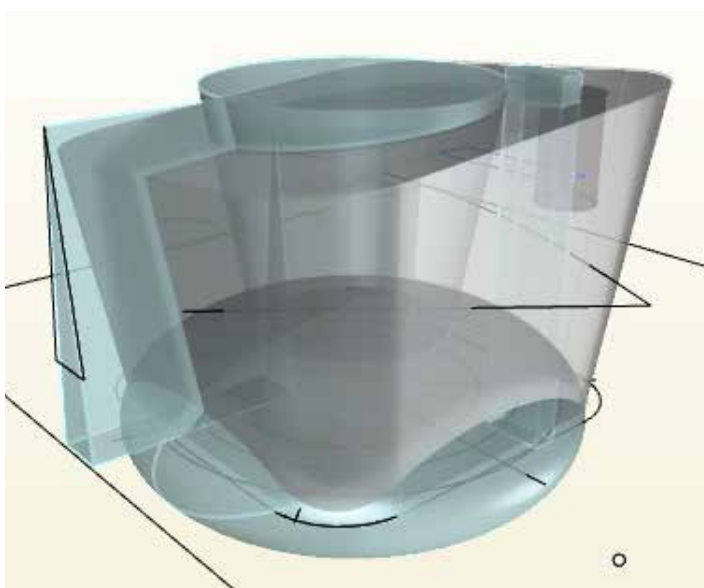

A conceptual arrangement of mass and void elements

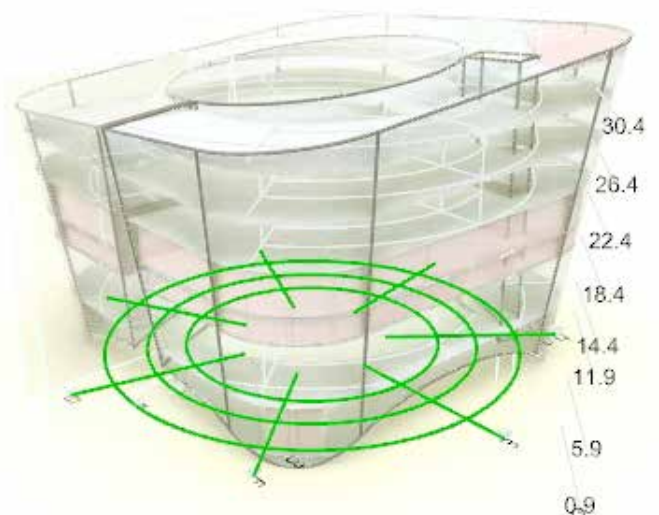

The resolved concept model

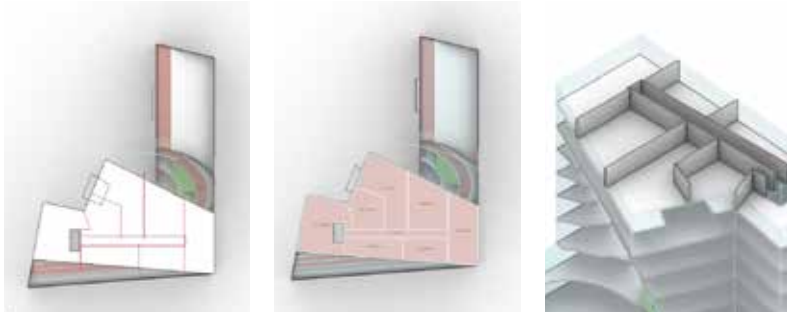

Programming : Curves to Spaces to Walls (if desired) : and on to native elements in a BIM environment when the project advances



<https://www.food4rhino.com/en/app/day-1-bim-tools>

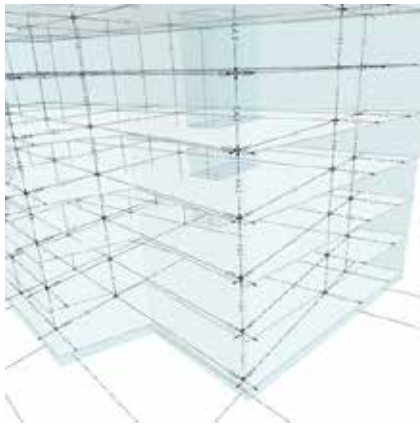

Structure:

While day1bim is not intended to be a structural analysis tool, the structure component does a very good job of quickly aiding the user to visualize the entire structural wire frame of the building. It also determines quantities and generates the lengths of centerline geometry separated into columns and beams in two directions. The wireframe comes out fully tagged and, of course, this center line geometry once created, is immediately available to be linked forward to an FEA analysis.

**Elemental
Forms**

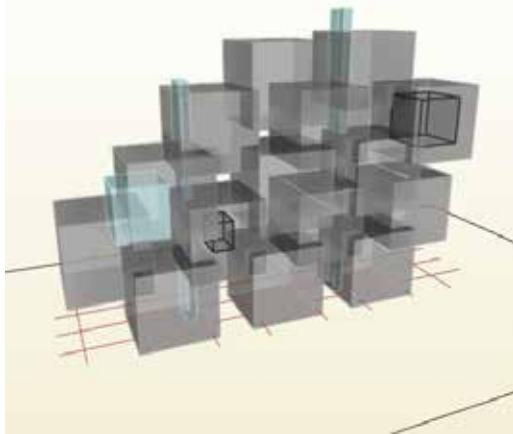

**Resolved
Concept
Massing**

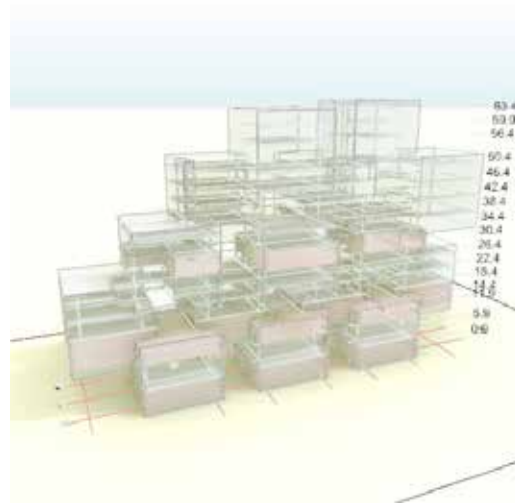

**A detail view
of complex
intersections**

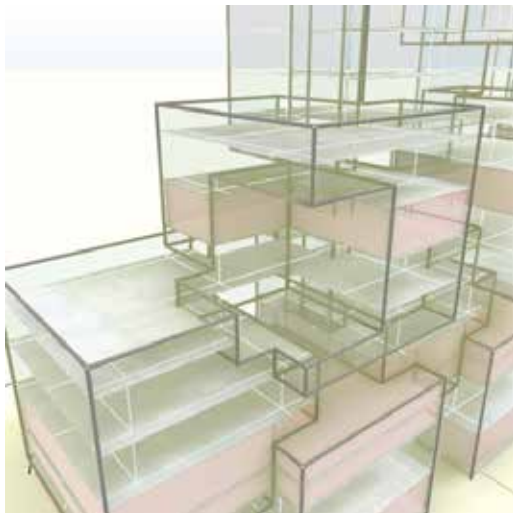

**Developed facade
isolated faces to
control geometry
for panelization**

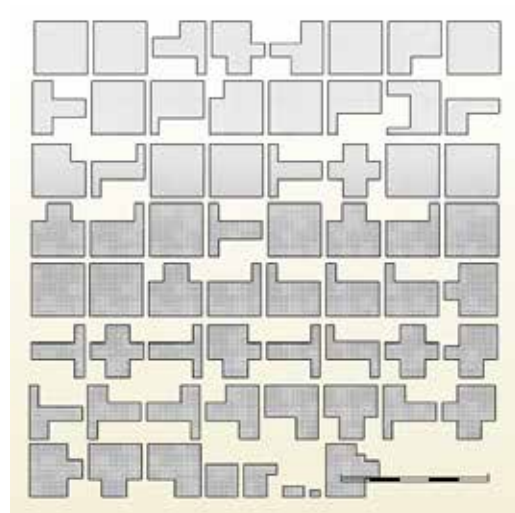

Cornell Inhabit:

Modular space
defining
installation /
display System

Furniture

Concept : Feel



Cornell INhabit - Wave

Proposal for a retail / expo space : Proposition d'un espace retail / expo



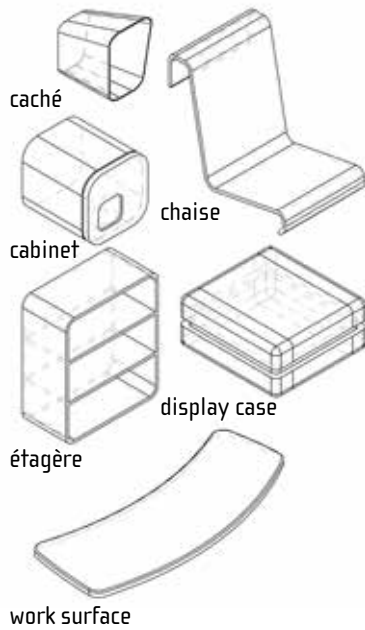

Configurations

Library

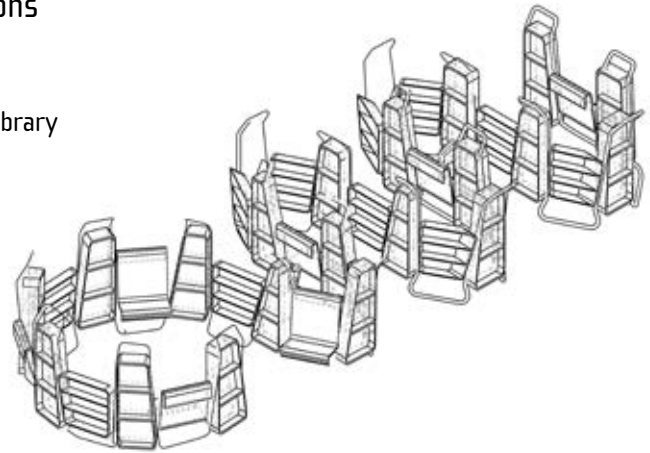

Retail / Expo

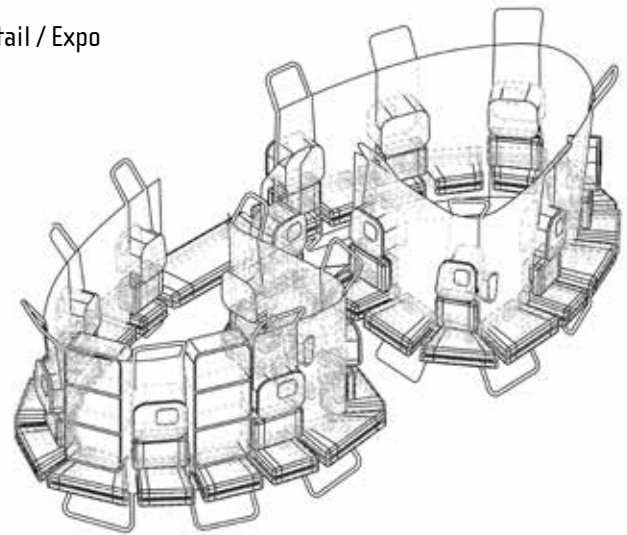

The Cornell InHabit system is an arrangement of components, which may include drawers, shelves, partially open boxes, as well as surfaces of a range of sizes from display to work surface. It could also incorporate display components such as vitrines. These elements are arrayed in irregular looking balanced composition. The overall arrangement could be used to define spaces such as in a work environment or retail space, activating a space with "Furniture". It could also be a focal point in space as a central display or in any number of variations on a table. The composition could be supported against a wall or free-standing. The system could be equally well used in a living environment in its functions of space defining and arranging of items, in a suitably open plan living arrangement.



Blend Vessel Project:

Variable Customizable 3D Printed

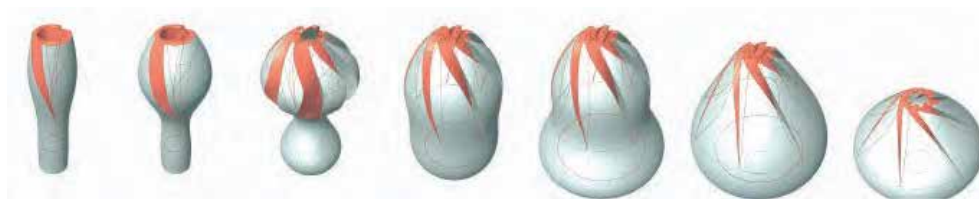
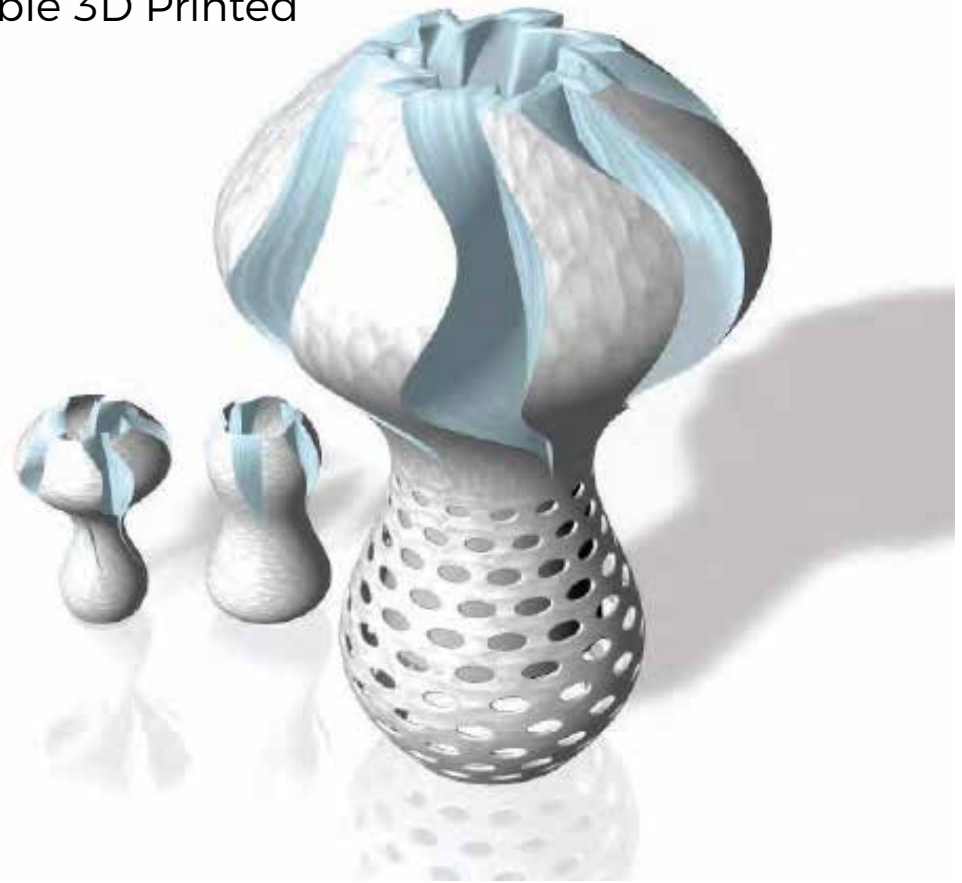

Research in variable design object
and ceramic 3D printing
European Ceramic Work Center:
Artist in Residence 2014

IC Lamp:

A luminous form in cast porcelain. Transformable and with LED lamps to create a surreal form and light.

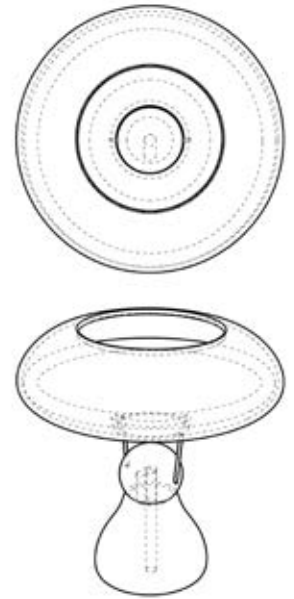
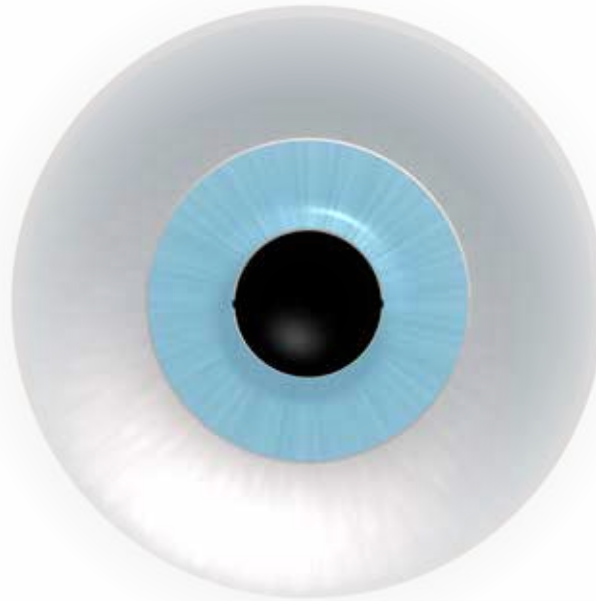

2 Part Chair

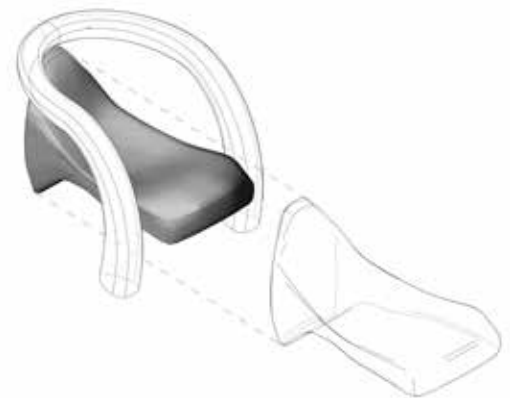

Haring & Tusk

Professional & Personal Projects:

Mixed Use housing - Underdevelopment in a metropolitan site in France: Client / Site Information withheld, currently in competition

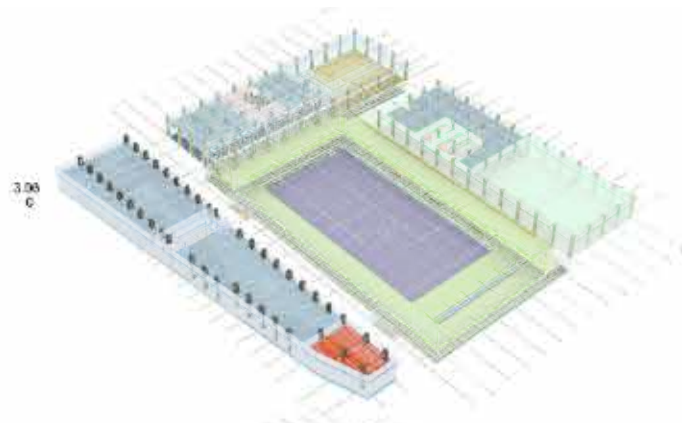
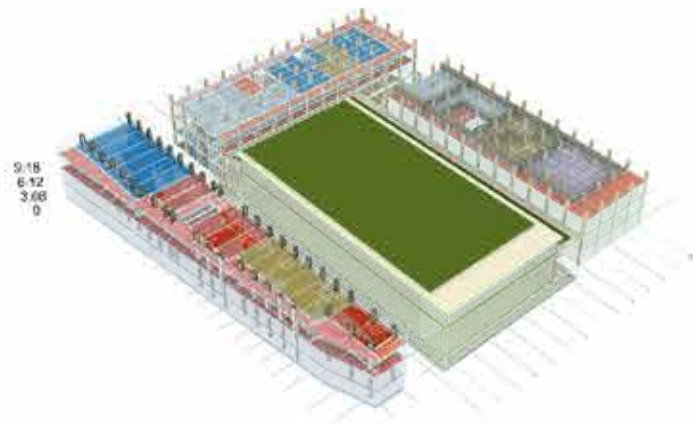

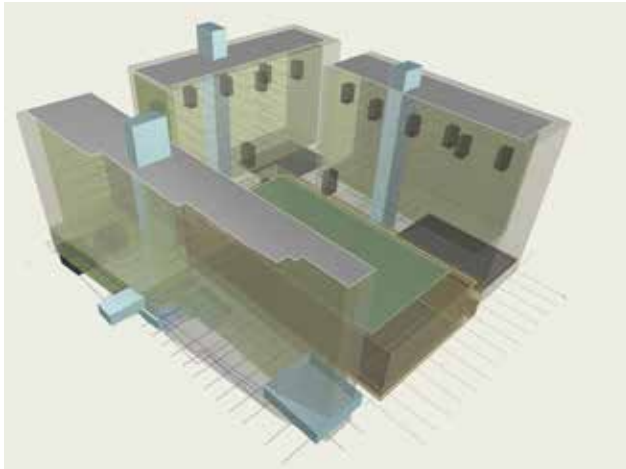

Volumetric Concept Massing
before application of the
algorithmic generative
design articulation tools

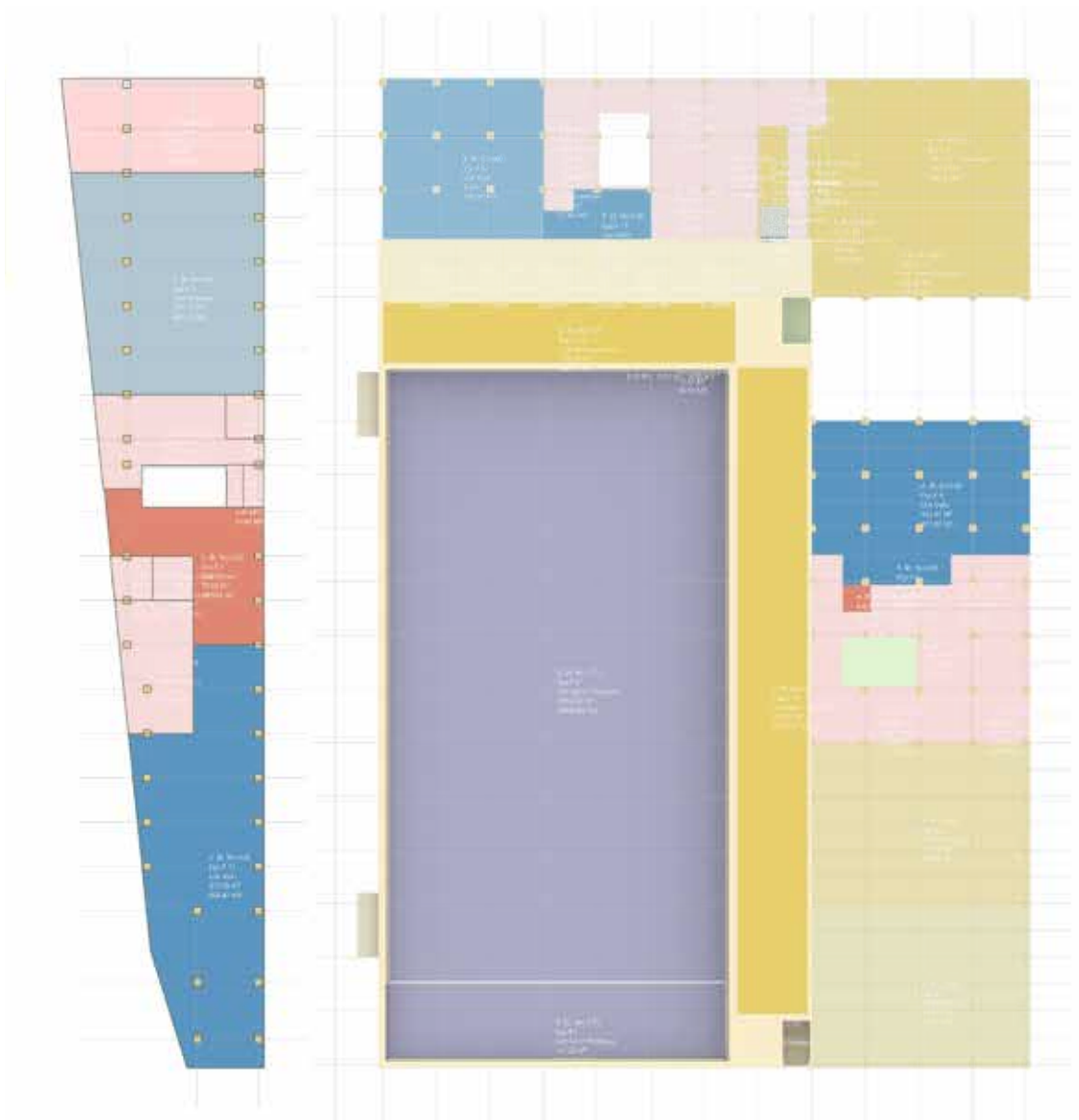

Competitions :

Amstel Bridge
Competition, 2009



Concept Image Adaptive
Urbanism, Cloud Shell
Grenoble, 2018



Asfluitdijk World
Sustainability Center
Competition, 2011

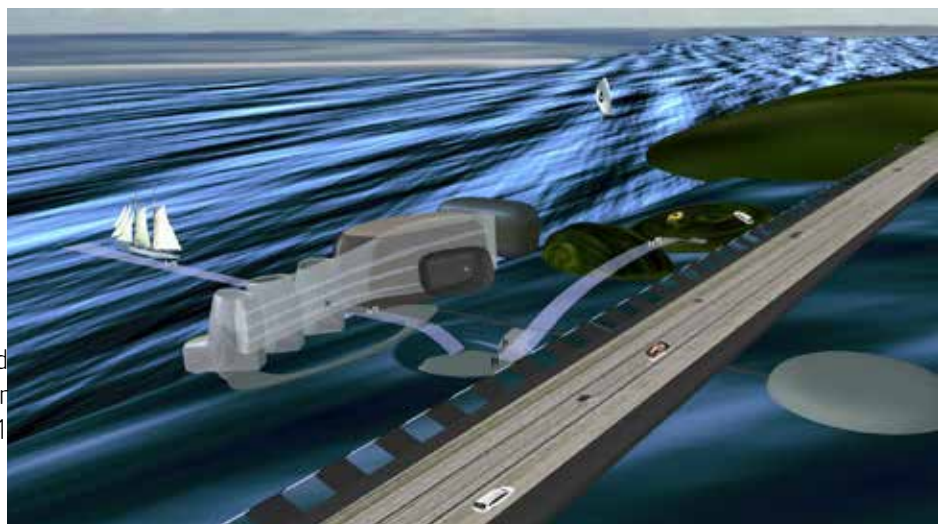

Julia Friedman Gallery :

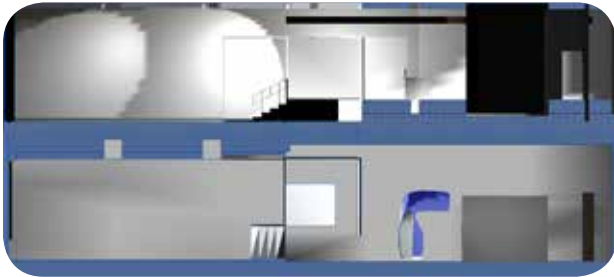

Design, fabrication
and installation for
a multimedia art
gallery
Chicago's West Loop
district. 2001

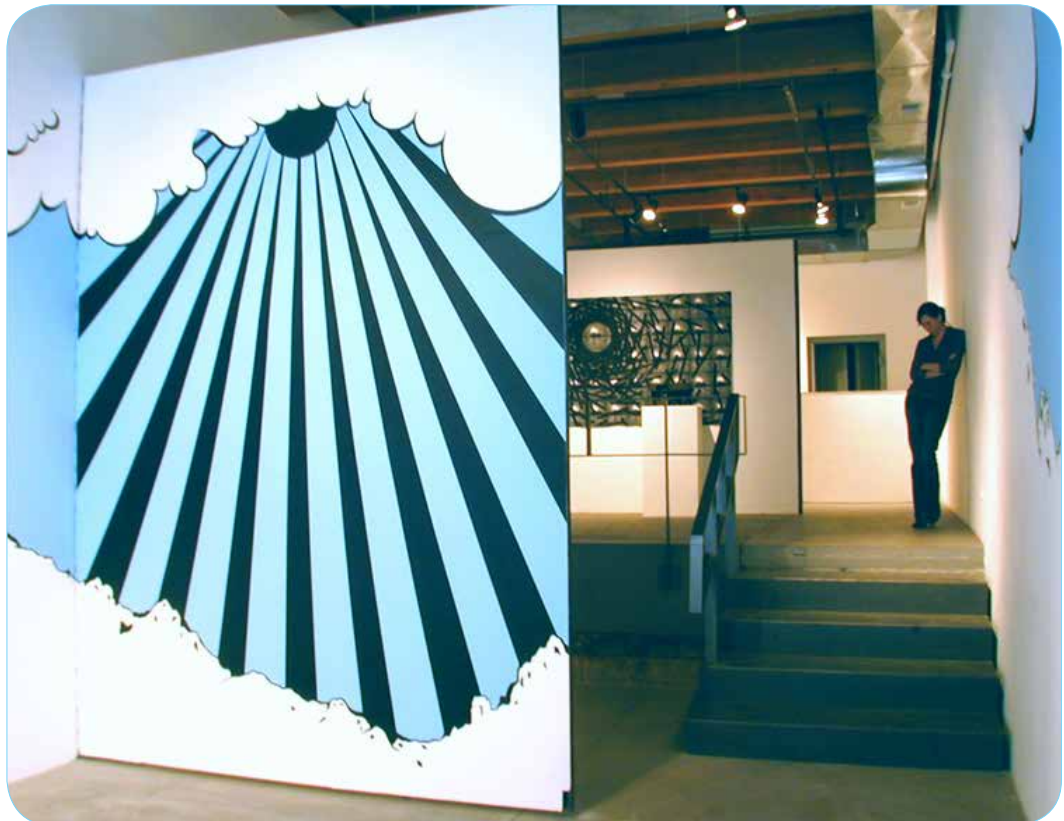



Princess Nourah Bint Abdul Rachman
University For Woman, Riyadh KSA
Academic Medical Center,
Centre Universitaire Hospitaliers
Project Architect



Academic

Flashpoint Media Arts Academy, Chicago Illinois
*Rénovation d'intérieur pour une école
du design multi-média,*
Project Architect



Parkland College Campus Extension
Student Union
Champaign Urbana IL.
Design & Project Architect



Case Western Reserve
University Student
Union - Architectural
Interior Features
Design & Coordination



William Jones College Preparatory High School,
Chicago Illinois
Façade Design & Coordination ,
Conception Du Façade et Development Technique



Round Rock Cedar Ridge High School, Round Rock Texas,
Lycée
Project Architect



Project Architect for
the construction of new
public school buildings,
Naperville, Illinois



King Abdullah Financial District
Riyadh KSA w/P+W
Mixed Use Tower 4.01
Tour à Usage Mixte 4.01
Project Architect



Towers

King Abdullah Financial District
Riyadh KSA w/P+W
Mixed Use Tower 4.10
Tour à Usage Mixte 4.10
Project Architect



Godfrey Hotel, Chicago Illinois, w/VDTA
18 story hotel staggered steel truss structure
Project Architect

Garmin USA, Chicago Retail interior

Design of display fixtures, Digital Fabrication of interior wall structure.

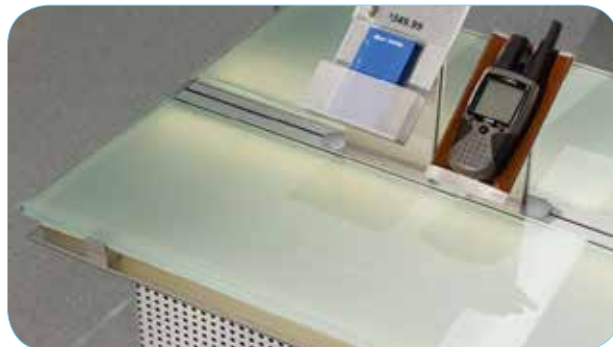

Detailed Fabrication : Modeling

Zaha Hadid / SANAA

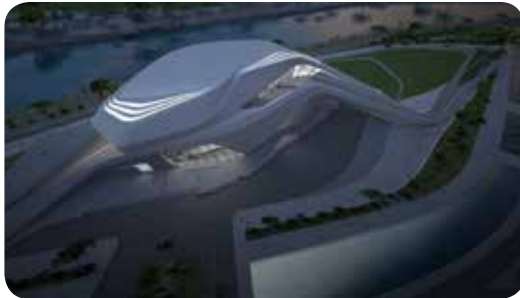

Grand Théâtre de Rabat de Zaha Hadid Architects

Detailed modeling for interior finished constructions: preparation of all components for direct digital machining. Project of Zaha Hadid Architects "Théâtre National De Maroc" In consultation to Aurblanc Lyon, FR. 2019

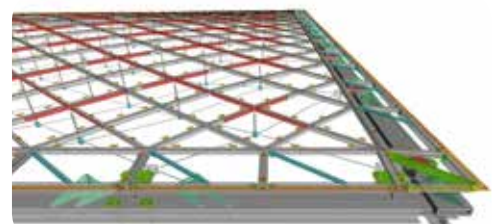
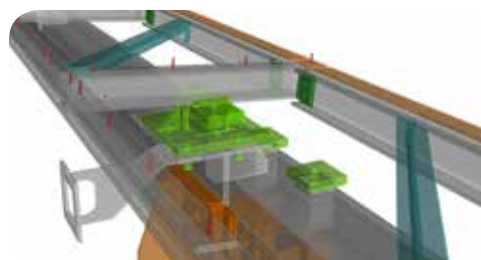
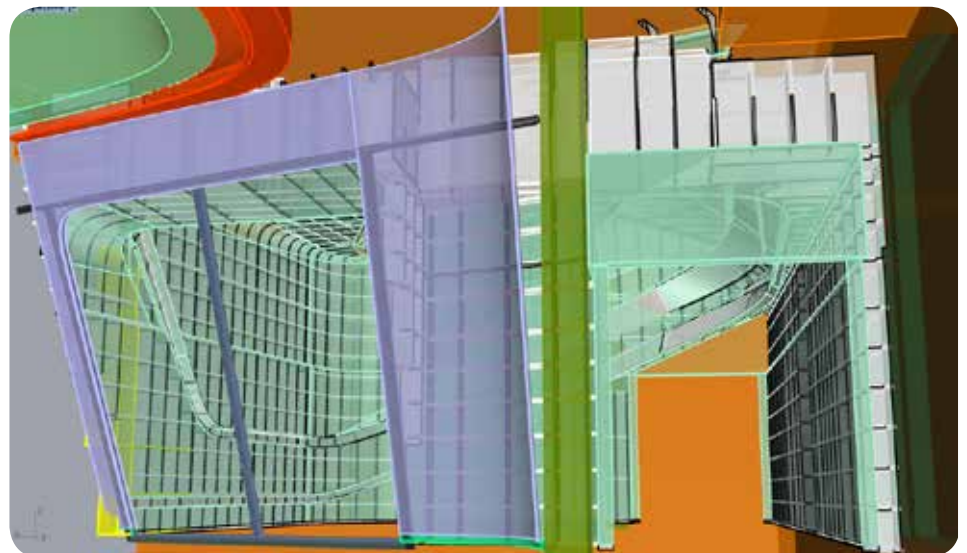

The detail modeling and translation to digital fabrication of all of the elements for the structure of double curved glass roof systems. In consultation to Bollinger Grohmann Engineers, Paris Office

Wildcard : Parametric Exquisite Corpse

In class midterm exercise November 7th
AIADO : 3917 Parametric Modeling :
Grasshopper / Rhino
Fall 2013

An experiment sharing algos between
students which yielded unexpected
results

Parametric Exquisite Corpse

Among Surrealist techniques exploiting
the mystique of accident was a kind of
collective collage of words or images
called the cadavre exquis (exquisite
corpse). Based on an old parlor game,
it was played by several people, each of
whom would write a phrase on a sheet
of paper, fold the paper to conceal part
of it, and pass it on to the next player
for his contribution. [Dada & Surrealist
Art," by William S. Rubin]

